

AVANT[®]

Wood chipper CH100 Operator's Manual 2017-

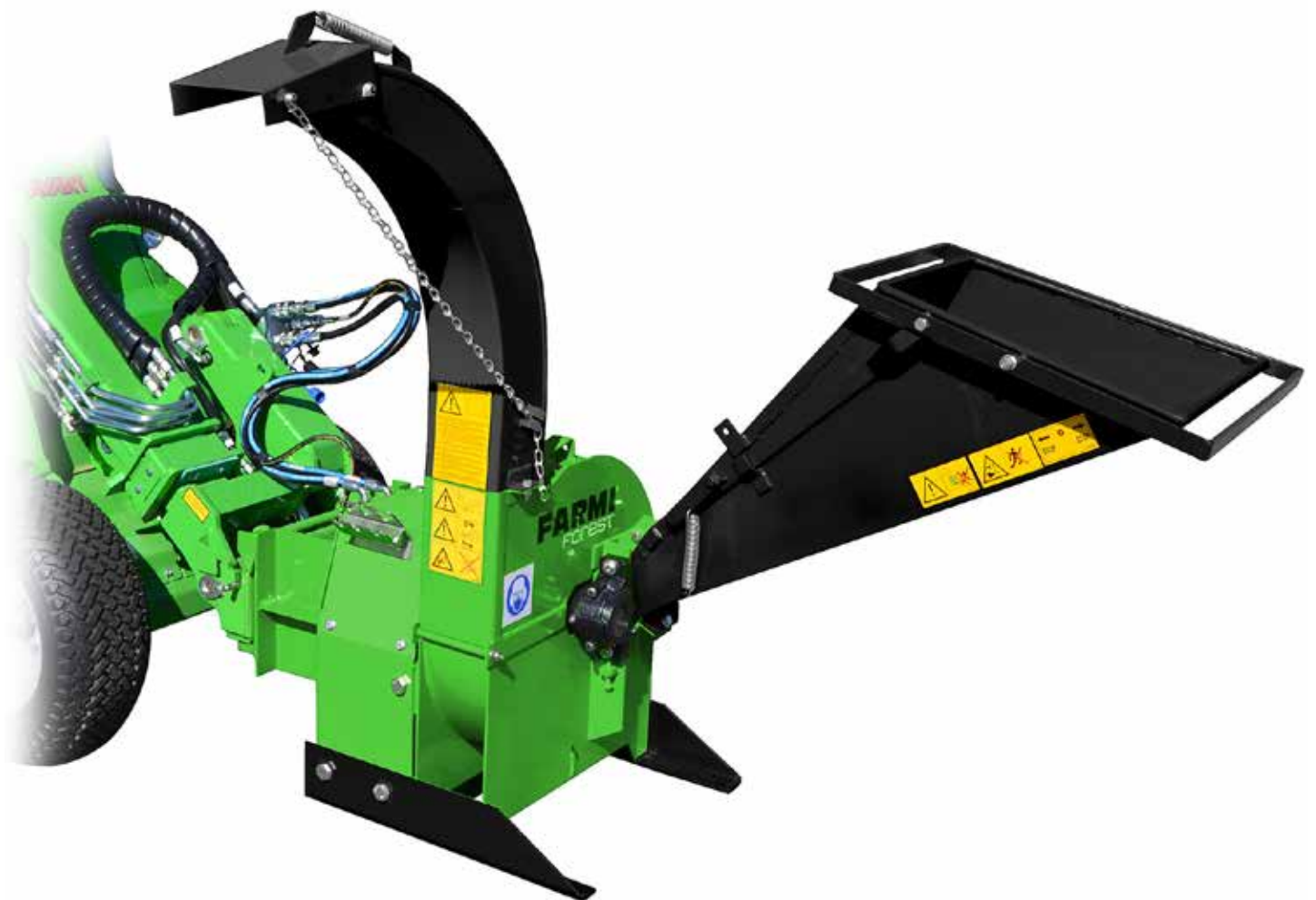

WARNING SYMBOLS IN THIS MANUAL



- imminent danger which could cause serious personal injury or death



- danger which could cause personal injury



- conditions or misuse that could damage equipment or machinery
- reminders, such as for performing checks or carrying out maintenance or repair procedures

INTRODUCTION

This manual includes the information and maintenance instructions required for operating the machine in the optimal manner.

Although you have experience in using this kind of machinery, read the operation and maintenance instructions carefully since they include information enabling efficient and safe operation. Regular maintenance is the best way to guarantee the efficient and economical performance of the machine.



Each and every operator must read, understand, and follow all safety instructions and procedures.

PRODUCT WARRANTY

Avant Tecno Oy provides a 12-months warranty on CH100.

CUSTOMER FEEDBACK

We are happy to receive your opinions and suggestions for improvements by mail, fax or e-mail. All implemented suggestions for improvements will be rewarded.



EC DECLARATION OF CONFORMITY

Translation of original Declaration of Conformity

Manufacturer:

Farmi Forest Corporation
Ahmolantie 6, FIN-74510 IISALMI, Finland

Person authorized to compile the technical documentation:

Name: Matti Berg
Address: Ahmolantie 6, FIN-74510 IISALMI, Finland

Commercial name:

Farmi

Commercial name:

Farmi wood chipper with attachable Farmi feed hopper

Machine type:

Wood chipper: FARMI 100

Available feed hoppers for manual feed: F100

Machine series number:

Herewith, we declare that the machine brought into circulation conforms with the pertinent requirements of the Machinery Directive 2006/42/EC and the EMC Directive (directive relating to electromagnetic compatibility) 2004/108/EC.

The following harmonized standards have been applied for the conceptional design of the machine:

SFS-EN ISO 12100-1/2, SFS-EN ISO 13857, SFS-EN 13525, SFS-EN ISO 4254-1

The following additional standards and specifications have been applied for the conceptional design of the machine:

SFS ISO 730-1, SFS ISO 2332

Iisalmi

(Place)

26.2.2015

(date)

Juha Halivuori

TABLE OF CONTENTS

| | |
|---|----|
| GENERAL SAFETY INSTRUCTIONS | 5 |
| GENERAL SAFETY INSTRUCTIONS FOR THE CHIPPER | 8 |
| STICKERS AND PLATES | 9 |
| CH100 - GENERAL DESCRIPTION AND INTENDED USE | 12 |
| MOUNTING | 14 |
| LIFTING | 14 |
| ASSEMBLY INSTRUCTIONS | 15 |
| MOUNTING OF THE CHIPPER AND PRE-OPERATION INSPECTIONS | 16 |
| MOUNTING OF THE CHIPPER TO AVANT LOADER | 17 |
| CONNECTING AN DISCONNECTING HYDRAULIC HOSES | |
| STARTING THE CHIPPER | 22 |
| CHIPPING | 23 |
| OPERATION OF CHIPPER AND FEED UNIT | 23 |
| EMPTYING THE CHIPPER AFTER USE | 24 |
| SWIVELING THE FEED HOPPER TO THE TRANSPORT POSITION | 24 |
| STORAGE OF THE CHIPPER | 24 |
| MAINTENANCE | 24 |
| REPLACING THE BEARING | 25 |
| ADJUSTING THE BEARING CLEARANCE | 26 |
| KNIFE AND ANVIL MAINTENANCE | 29 |
| CH100 CHIPPER | 34 |
| DISC, COMPLETE | 36 |
| CH100 BEARINGS | 37 |
| BELT DRIVE FARMI 100F i=2,0 | 38 |
| DISCHARGE CHUTE | 40 |
| HYDRAULIC MOTOR AND HOSES, OPTIONAL EQUIPMENT | 41 |
| CH100 HYDRAULIC OPERATION, OPTIONAL EQUIPMENT | 42 |
| PRODUCT REGISTRATION FORM | 46 |

When ordering spare parts, please indicate machines type from the machine plate, spare parts order number, description and quantity required.

GENERAL SAFETY INSTRUCTIONS

These safety instructions are meant for the owners of Avant equipment, as well as those who operate, service or repair it.

The instructions help with:

- using the machine safely, appropriately and effectively
- identifying, avoiding, and preventing potentially dangerous situations

The manufacturer supplies an instruction manual, which must always be available at the place of operation of the machine. Each user must read the safety, maintenance and operating instructions before operating the machine, and comply with these instructions at all times.



Ensure that every operator of the machine is familiar with the content of the instruction manual and situation-specific safety instructions, and has been suitably trained before operating the machine.

The machine complies with technical requirements and applicable safety regulations. However, incorrect use, maintenance or repair of the machine may cause risks.

In addition to the instruction manual, remember to comply with regulations of the local occupational health and safety authorities, and with your country's laws and decrees.

The manufacturer is not liable for damages caused by:

- incorrect, negligent or inappropriate use of the product.
- non-original spare parts.
- normal wear and tear.
- misuse caused by an untrained person's improper actions.
- alterations made without the manufacturer's permission.



Written authorization must be requested from the manufacturer for any alterations to the machine.

STARTING

- Familiarize yourself thoroughly with the use, operation and controls of the machine and its equipment before starting.
- Familiarize yourself with the capacities and limitations of the machine and its equipment.
- Do not use the machine unless you are completely familiar with its operation.
- Be aware of the machine's danger zones.
- During operation, prevent bystanders from entering the danger zone.
- Ensure that each operator has the necessary safety equipment, such as a helmet, safety goggles, work safety boots and suitable protective clothing.
- Never wear loose clothing around moving parts. Protect long hair!
- Ensure that work is carried out according to the stipulations of applicable occupational health and safety legislation.
- Before starting up or using the machine, ensure that it cannot cause a risk to other people or property.
- Perform a safety check on the machine before every use. If you observe any faults or deficiencies, repair the machine immediately.
- Before operating the machine, ensure that there are no foreign articles in it.
- Place the machine on a hard, level surface for operation. In the winter avoid working in slippery areas
- Before mounting and using the machine, check the PTO drive shaft for correct condition and attachment.
- Never use a faulty or deficient machine.

TRANSPORT

- Before driving with the machine, ensure the safe mounting of the machine. Make sure that the journals are seating correctly and that the pins are tight. Check the tension of the lower link stabilizers.
- Before driving with the machine, make sure that the required lamps and reflectors as well as the slow moving vehicle sign are attached correctly. Moreover, the lamps should be checked for correct functioning.
- Before driving with the attached machine, make sure that the hydraulic unit of the machine is depressurized (unless otherwise instructed in the operating instructions).
- When driving on public roads, always observe the valid traffic regulations. The travel speed must be adapted to the specific conditions.
- When driving, please take into consideration the additional mass resulting from the machine's weight and their effect to the manoeuvrability and braking capability of the loader.
- Please note that the machine rear sways when turning.
- Pay attention to the machine's height near bridges or other height restricting objects.
- When backing off, the machine may obstruct the rear view. Exercise extreme caution. If necessary, ask a flagman to help you; he can indicate the required distances.
- It is prohibited for other people to ride on the machine.

- Never insert any body part into the machine with the engine running.
- If any faults arise that may jeopardize occupational safety, turn off the machine.
- During operation, the machine's operator is responsible for safety in the whole work area. Work may not be carried out in the presence of any factors that jeopardize occupational safety.
- Exercise extreme caution when hitching / unhitching the machine from a tractor/trailer.



The machine's operator must have constant, unobstructed visibility of the work area. If this is not possible, the operator must work with an assistant.

- Look out for moving parts when the machine is in operation.
- Secure the machine against unauthorized and accidental operation (e.g. moving when parked) whenever it is left unattended.
- Never leave the machine running unattended.
- Avoid causing fast, stroke-like loading.
- Never exceed the given operating values.
- All safety and warning signs on and in the machine must be legible and intact.
- The machine may not be operated by persons who are unwell or under the influence of drugs or alcohol.

OPERATION



Many occupational accidents take place in abnormal circumstances. Therefore it is important to take into account all the possible circumstances that may arise during operation of the machine.

- Depending on the machine's type, it will have diverse safety devices and protectors. These are meant to protect the machine and its operator, and they must never be removed or altered. Never start up or use the machine without all the safety devices and protectors in place.

MAINTENANCE

- The machine may only be serviced and repaired by professionals.
- Electrical and hydraulic faults may only be repaired by authorized professionals.
- In cases requiring welding, contact the manufacturer.
- Turn off the tractor engine and disconnect the universal joint before beginning service or maintenance actions.
- Before any maintenance work, turn the main power switch of the tractor to OFF.
- Ensure that there is no pressure in the hydraulic system.
- Take out the key from the tractor's ignition for the duration of the servicing or maintenance. Check that the power is off from the machine you are working on.

- When servicing the machine, place it on a level surface and ensure that it cannot be moved.
- Observe the service intervals and annual safety inspections.
- All spare parts and equipment must fulfill the manufacturer's requirements. This can be guaranteed by using original parts.
- Put all safety devices back into place immediately once servicing or maintenance is complete.



When lifting the machine, check that the lifting/hoisting equipment is in perfect working order. Check the weight of the machine before lifting it. Choose lifting trajectories so that they do not cause any danger.

Many countries have specific legislation on lifting, hoisting cables and hoists. Always comply with local safety regulations.

OILS AND LUBRICATION

- Always use the oil types recommended by the manufacturer. Other types of oil may cause faults or improper operation of the equipment, which could lead to serious damage to people or property.
- Never mix different liquids or oils.
- Always follow the manufacturer's lubrication instructions.
- Use control equipment carefully until the hydraulic oil has had time to reach its operating temperature.

SAFETY INSTRUCTIONS FOR HYDRAULIC CIRCUITS

1. Work on hydraulic equipment may only be carried out by professional hydraulic engineers.
2. Be cautious when using the equipment in cold conditions.
3. Check the machine for leaks. Do not use the machine if there is a leak from any system. Check all hydraulic hoses – particularly those which are bent during use – and replace any that are in poor condition or have leaks. Ensure that all joints are tight and that the lines are not damaged. Check the hose sheathing for damage. Check that all protective caps and filler caps are closed properly.
4. Check that all hose connectors, lengths and qualities comply with applicable requirements.

When replacing or repairing hoses, use original parts or hoses and connectors recommended by the manufacturer. Check particularly that the pressure classes of the hoses and connectors are suitable to the operating pressure levels.

5. Check that all safety devices such as pressure relief valves, etc., are in place and work properly. Familiarize yourself with their use. Safety systems may never be bypassed.
6. Check the main hydraulic parts daily, and always after a fault. Replace any damaged parts immediately.
7. If a component is damaged, clean it before repairing it. Do not use solvents when cleaning parts.
8. Do not attempt to carry out repairs that you are not fully familiar with.
9. Never carry out repairs of the hydraulic circuit when the system is pressurized. When pressurized, the oil spray can penetrate the skin and cause mortal danger.
10. Never work below a device or component that is only being held up by hydraulics. Use separate supports when carrying out maintenance or repairs. Do not disconnect cylinders or their valves until the machine is well supported.
11. Most hydraulic oils do not evaporate easily. Risk factors include hot oil, spills and oil mist (pressurized).
12. If oil gets into your eyes, rinse with plenty of water and contact a doctor.
13. Avoid prolonged or repeated contact with your skin.
14. If sprays or contact with the skin cannot be avoided, use protective gloves, goggles and clothing as necessary. Do not use oily clothing.
15. Avoid discharging hydraulic oil into the environment, as it can pollute waterways and the groundwater. If biodegradable oil is to be used, please contact the manufacturer beforehand and have the suitability of your equipment for the operation with biodegradable oil confirmed by him before such oil is used.
16. Store the oil in sealed containers provided by the manufacturer. Try to transfer the oil directly from its container into the tank.
17. If the oil must be passed through other containers, ensure that they are completely clean. Caps, funnels, sieves and filling holes must also be clean.
18. Never store oil outdoors, as water could condense in it.
19. Always dispose of oil in a suitable container, never into the environment!

GENERAL SAFETY INSTRUCTIONS FOR THE CHIPPER

The noise level at the operator's area may exceed 70 dB(A). Wear hearing protection!

- Please make sure any machine operator has the required personal protective equipment: safety helmet, protective goggles, cut resistant safety boots and required protective clothing.
- The chipper must not be used without being mounted to a tractor. It is prohibited to mount the chipper to another power source.
- It is not permitted to operate the chipper without feed unit or feed hopper.
- Indoor operation of the chipper is prohibited.
- Always keep a safe distance to the discharge position of the chips.
- Detach the chipper from the tractor before performing any maintenance or repair works.
- Do not remove, lock, disable or modify in any other way the stop lever of the feed unit.
- The feed hopper or the feed unit must not be mounted at a higher or lower position as this would impede the stop lever function.
- Note that the loader boom can be lowered or tilted even if the engine has been shut down. Never allow anyone to get under the raised load or the loader boom.
- Always lower the attachment on the ground before leaving the driver's seat.
- Check the general condition of the attachment and the loader, and check for possible hydraulic oil leaks. The attachment must not be used, if there is a fault in the hydraulic system of the loader or the attachment. Keeping the equipment clean reduces the likelihood of blockages.
- Always transport the attachment as low and close to the ground as possible. Note the effect of heavy load at the front of the loader to the stability and handling of the loader.
- Choose a level and well lit working site, which can carry the load of the equipment and the logs.
- The operating area must be even and it must not be slippery. Clear the area from any obstacles that could cause a tripping hazard.
- Operate the log cutter/splitter in daylight or outdoor area with good artificial light.
- Ensure that the loader and the attachment are used in a safe and intended manner.
- Smoking near the operating area is prohibited.
- Do not allow children to operate the equipment.

STICKERS AND PLATES

These plates and stickers must be found on the chipper. Replace missing plates or stickers immediately.

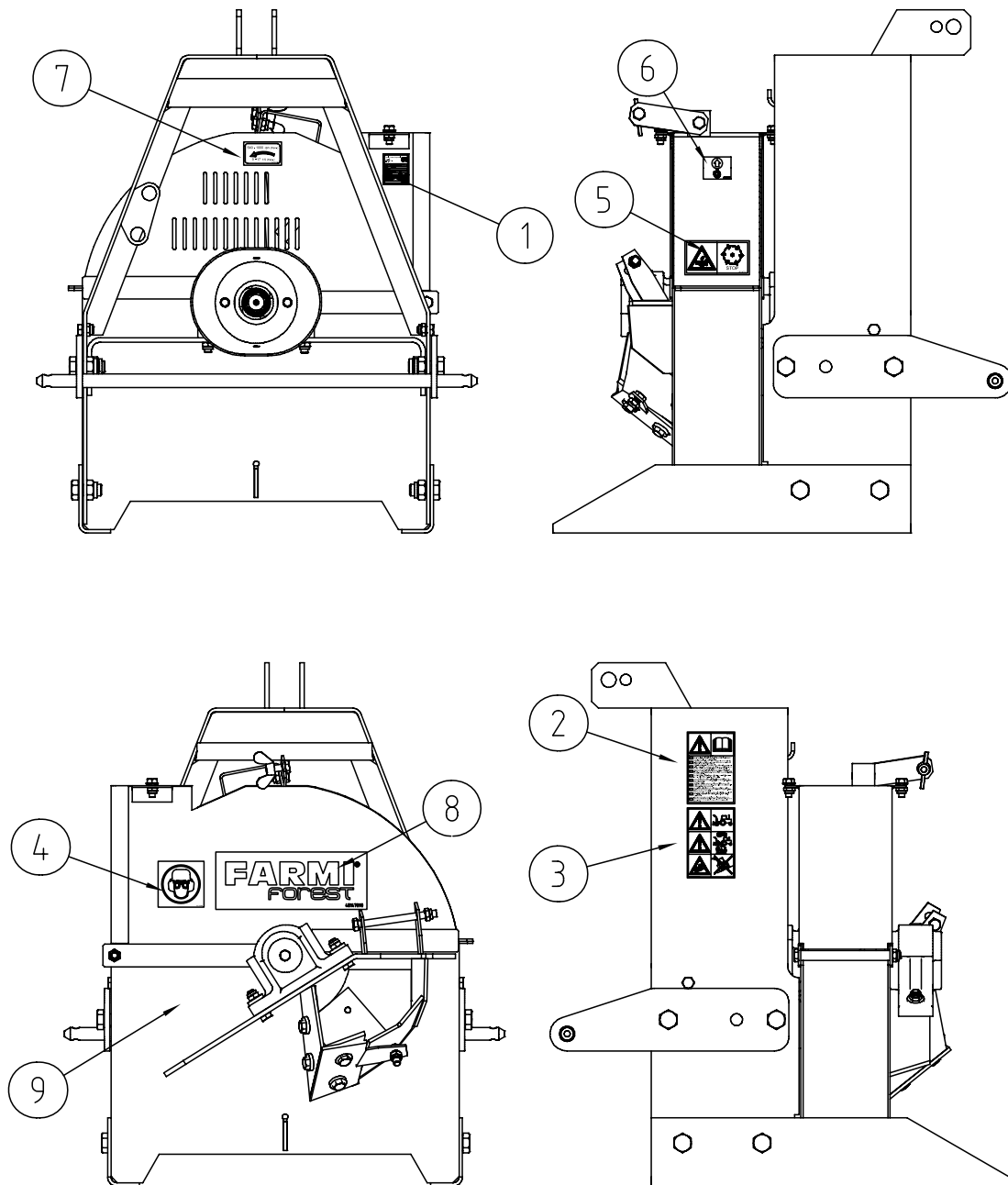



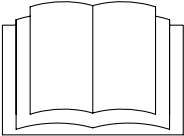

| | | |
|---|--------------|---|
| Farmi Forest Corporation Ahmolantie 6 FIN-74510 IISALMI FINLAND | |  41010100 |
| TYPE | WOOD CHIPPER | |
| MODEL | 100 | 150/+35/+40 OEM/3-POINT/BT |
| FEEDER | F100 | 30 |
| SERIAL NO. | | |
| YEAR OF MANUFACTURE | | 20 |
| POWER NEEDED | | 8.5-40 kW |
| MAX. HYDR. PRESSURE | | 175 bar |
| OIL FLOW NEEDED | | 30 l/min |

1. Machine plate CH100 (41010100)

| | |
|---|---|
| 40147020 | |
|  |  |
| GB | Please read the operating instructions of the machine meticulously before you operate, maintain or repair the machine. During machine operation, please observe the operating and safety instructions. |
| DE | Lesen Sie vor dem Betrieb, der Wartung oder Reparatur der Maschine die Betriebsanleitung sorgfältig durch. Beachten Sie während des Betriebs die Bedienungs- und Sicherheitsanweisungen. |
| FR | Veillez lire les instructions de service de la machine méticuleusement avant d'utiliser, d'entretenir ou de réparer la machine. Lors du fonctionnement de la machine, veuillez observer les instructions de service et de sécurité. |
| IT | Leggere scrupolosamente le istruzioni per l'uso della macchina prima di attivare la macchina, prima di eseguire la manutenzione o la riparazione della macchina. Durante il funzionamento della macchina, osservare le istruzioni per l'uso e per la sicurezza. |
| FI | Lue käyttöohjeet huolellisesti ennen kuin käytät, huollat tai korjaat konetta. Noudata käytön aikana käyttö- ja turvallisuusohjeita. |
| SE | Var god läs igenom maskinens driftsinstruktioner noggrant innan du kör, underhåller eller reparerar maskinen. Följ drifts- och säkerhetsinstruktionerna när maskinen är i drift. |
| NO | Vennligst les driftsinstruksjene for maskinen nøye igjennom før du driver, vedlikeholder eller reparerer maskinen. Under driften av maskinen må drifts- og sikkerhetsinstruksjene overholdes. |
| DK | Læs betjeningsvejledningen for maskinen omhyggeligt, før du betjener, vedligeholder eller reparerer den. Følg anvendelserne vedrørende betjening og sikkerhed under brug af maskinen. |
| EE | Palun lugege masina kasutusjuhend enne masina käitamist, hooldamist või remontimist hoolikalt läbi. Masina käitamise ajal tuleb järgida käitus- ja ohutusjuhiseid. |
| RU | Перед использованием, техническим обслуживанием или ремонтом внимательно изучите инструкции по эксплуатации агрегата. В процессе работы агрегата соблюдайте указания по эксплуатации и технике безопасности. |

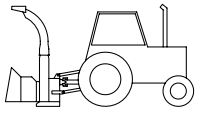
2. CAUTION!

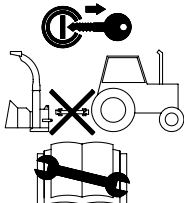
Please read the instruction manuals of the machine meticulously before you operate, maintain or repair the machine. During machine operation, please observe the operating and safety instructions. (40147020)

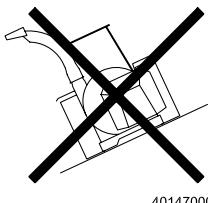
| | |
|---|---|
|  |  |
|  |  |
|  |  |
| 40147000 | |

3. (40147000)

CAUTION!

Before operation, mount the chipper to the quick coupling plate of the loader.

CAUTION!

Before maintenance and repair, please turn off the loader and disconnect the hydraulic couplings.

CAUTION!

Before detaching the chipper from the loader, it must be placed on a level surface.



4. Wear personal protective equipment. (40142080).

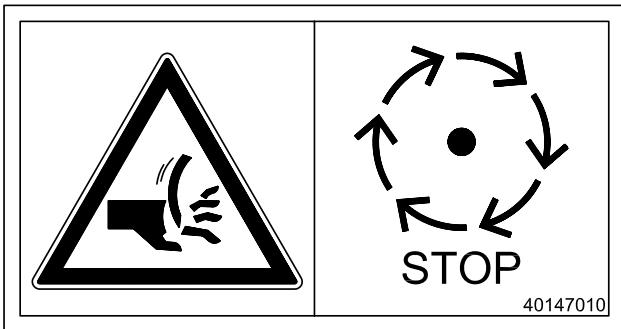

5. Cutting hazard! (40147010)

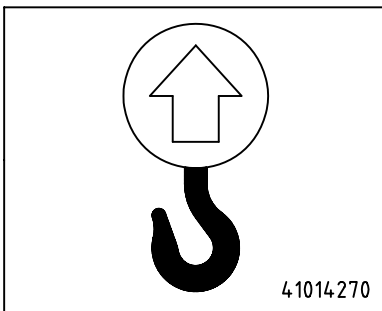

6. Lifting point sticker (41014270).

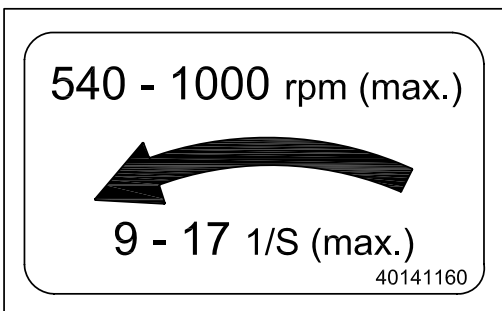

7. SPEED sticker (40141160).
Recommended speed range.
The rated speed must not be exceeded



8. FARMI Forest sticker (40147090)

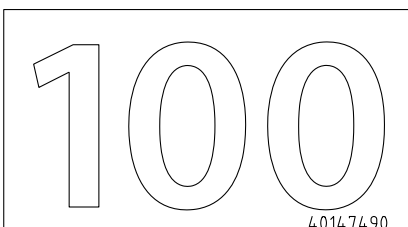

9. Sticker "100" (40147490)

CH100F - GENERAL DESCRIPTION AND INTENDED USE

CH100 is a single-disk chipper with two knives used for chipping wood with a diameter of up to 100 mm (chip size 12 mm). In addition, it is used to clear the embankments of roads and hiking trails as well as in gardening and landscaping.

A loader with a performance of 7.5 to 30 kW will suffice as power source.

This chipper model is hydraulically driven and can be used with the following Avant loader models:

220
225
225LPG
420
R20
520
525LPG
R28
528
630
R35
635
640
745
750
755i
760i

MAIN COMPONENTS OF THE CH100

1. UPPER CHAMBER
2. LOWER CHAMBER
3. CUTTING DISK
4. KNIFE
5. VERTICAL KNIFE
6. HORIZONTAL KNIFE
7. Puhallusputki
8. DISCHARGE PIPE LID
9. DRAWBAR
10. FEED HOPPER

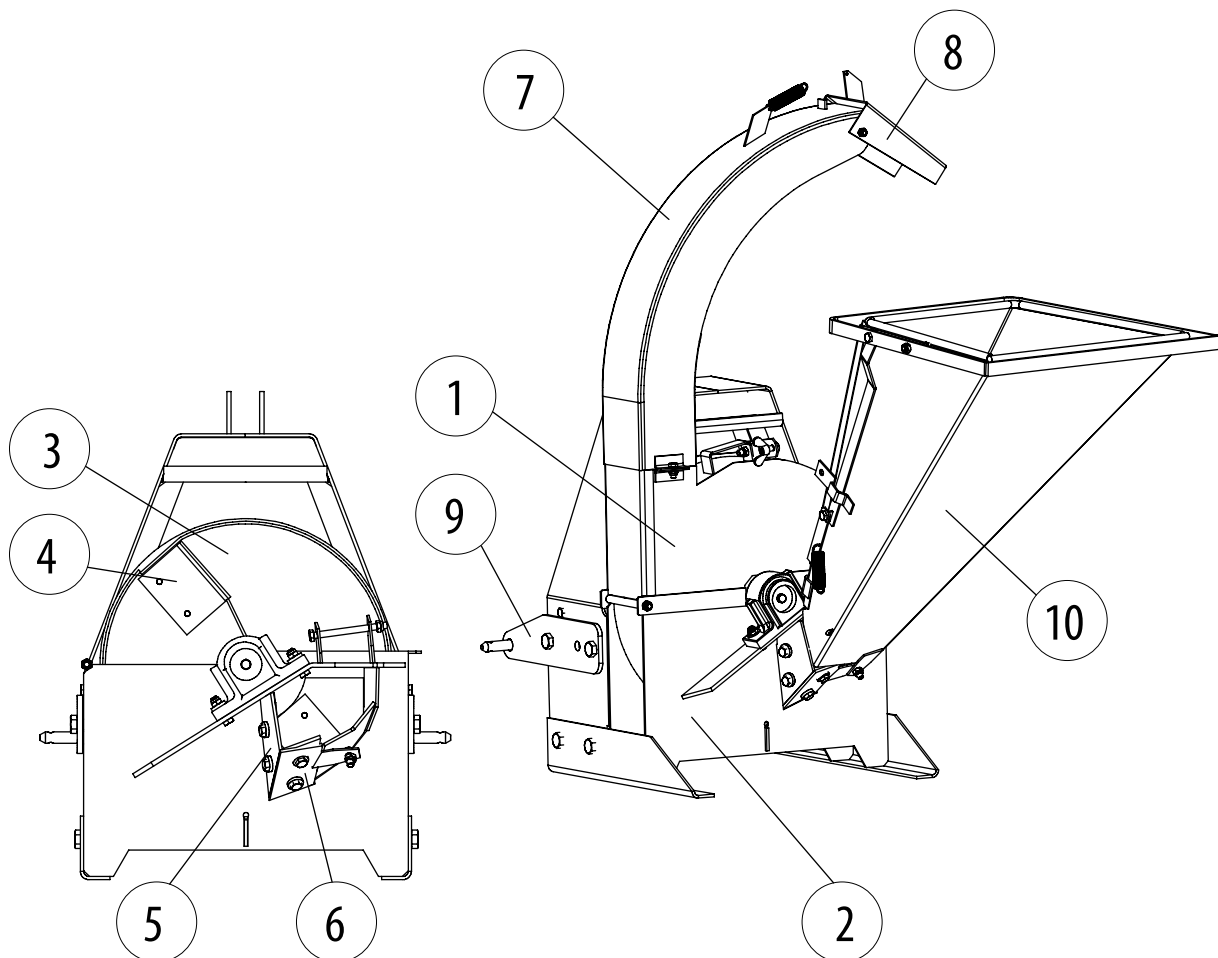
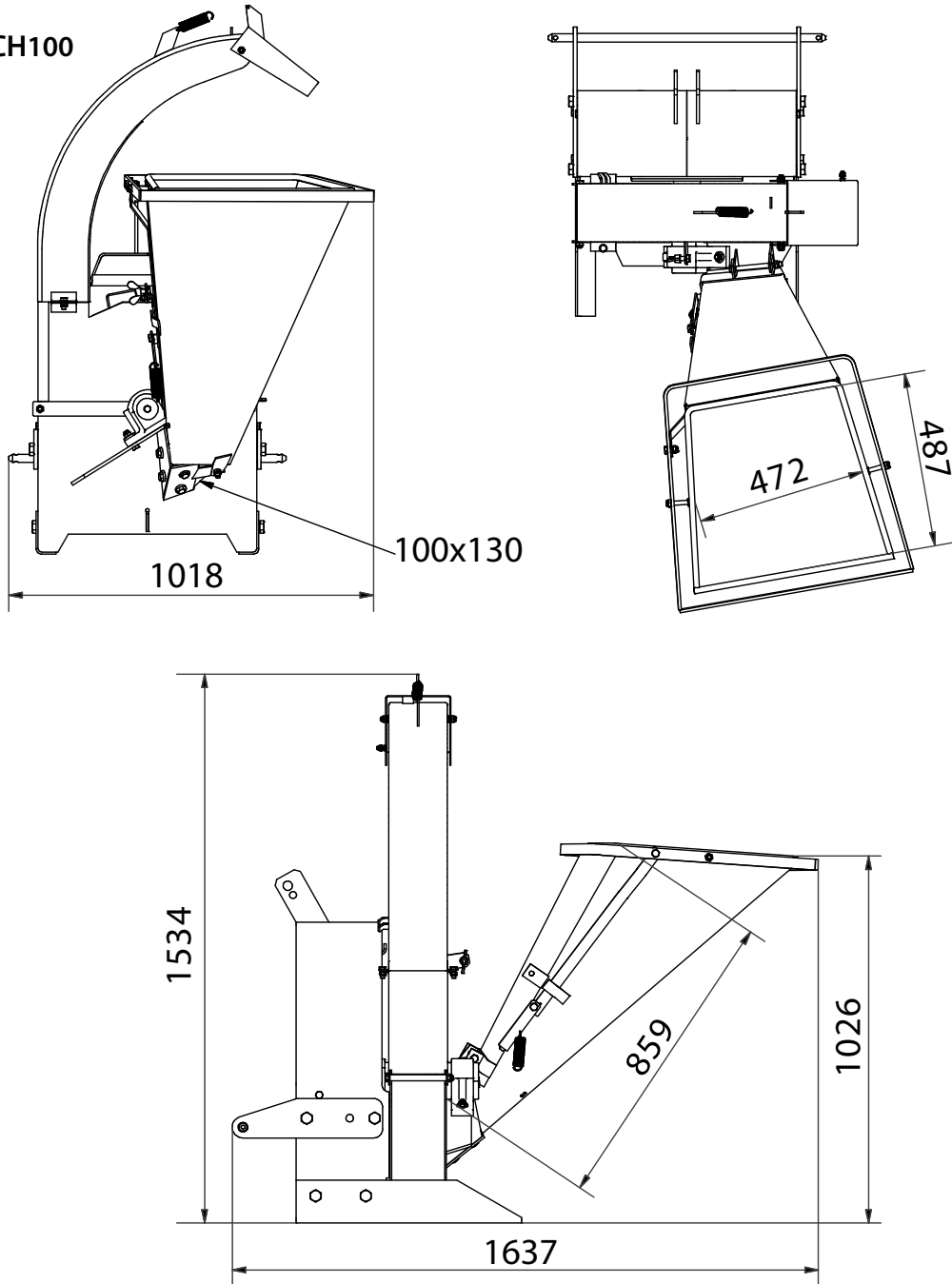

Fig. 1. Main components

AVANT[®] CH100

DIMENSIONS CH100



| TECHNICAL DATA | Chipper CH100 |
|-------------------------------|-------------------------|
| Type | disc chipper |
| Output | 0,5-2 m ³ /h |
| Chip length | 12 mm |
| Max. wood diameter | 100 mm |
| Tehon tarve | 7,5-30 kW |
| PTO rpm (if PTO driven model) | 540 tai 1000 rpm |
| Number of knives | 2 pcs |
| Power source | Avant loader |
| Mounting | Avant quick coupling |
| Chipper weight | 193 kg / 210 kg |
| Disc diameter | 550 mm |
| Terälaikan paino | 46 kg |
| Discharge pipe turning | to two sides |
| Feeder | drop spout |
| Noise emission | 104,2 dB (A) |

ASSEMBLY INSTRUCTIONS

LIFTING



Lifting points for each machine are marked with hook symbols.

Lift only using the proper type of lifting device and ensure that it has an appropriate lifting capacity.

Check the lifting slings, cables, and chains regularly.

Ensure that you know the weight of the load to be lifted and never exceed the lifting capacity stated by the manufacturer of the lifting device.

Select the transport routes for lifting so that the load is not transported over people or a location where people might be.

ASSEMBLY INSTRUCTIONS

1. Attach the feed hopper to the chipper using M12x120 and M12x30 hexagon head bolts and lock nuts. Lock the feed hopper in its operating position. Fig. 1.
2. Mount the discharge pipe to the chipper using two M10 bolts.
3. Mount the chipper to the quick coupling plate of the loader.

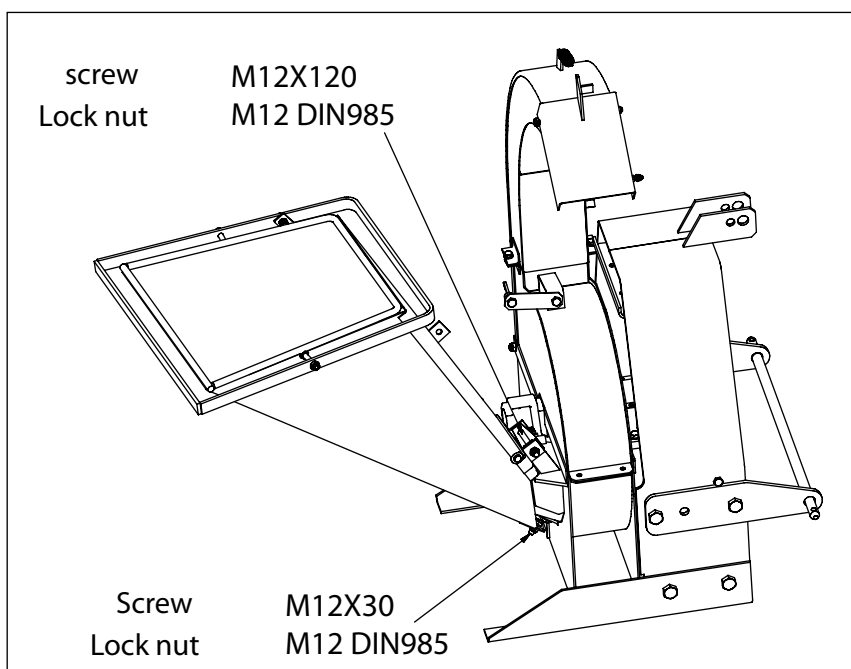

See fig 4. Installation of the feed chute / Chipping position

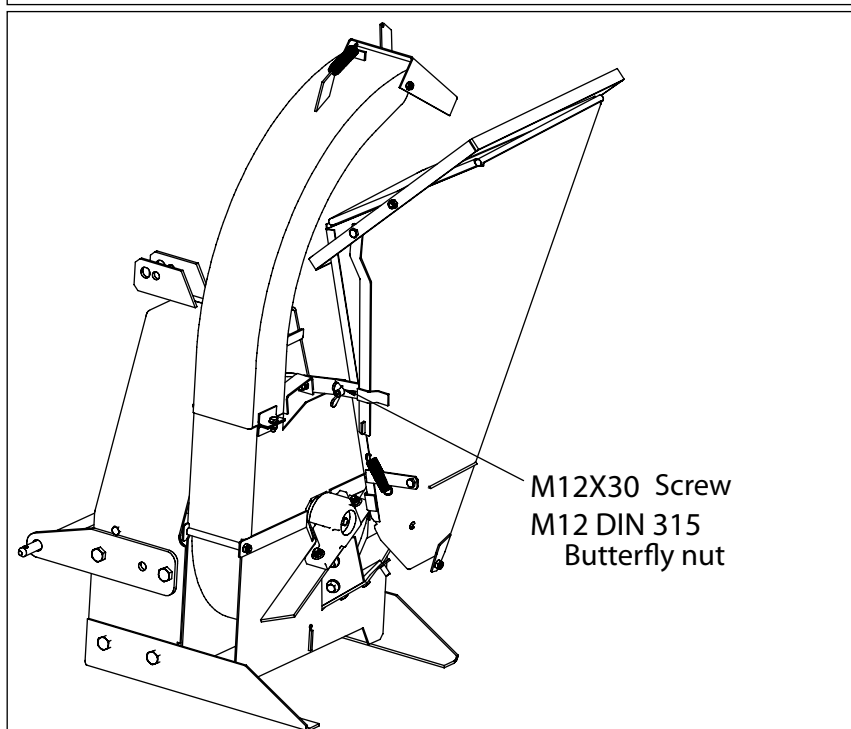

Fig. 4a. Installation of the feed chute / Transport position

MOUNTING OF THE CHIPPER AND PRE-OPERATION INSPECTIONS

1. For mounting or dismounting the chipper, always turn off the loader and apply the parking brake before entering the area between chipper and loader.
2. Make sure all protective and safety devices of the chipper are installed. Never remove any protective device during operation.
3. Before operation, please make sure there are no foreign objects in the feed hopper.
4. Before operation, please make sure there are no foreign objects in the chipper. Rotate the shaft to make sure that the cutting disk can rotate freely
5. Make sure that the water drainage holes on the lower chamber are open and that the disk is not frozen up.
6. During operation, the chipper must stand on level and hard ground.
7. Direct the discharge pipe so that the thrown out chips do not pose a risk to the operator of the chipper or to or anyone else. Always keep a safe distance to the discharge position of the chips.

MOUNTING THE CHIPPER ON AVANT LOADER

Coupling the attachment to the loader is quick and easy, but it must be done carefully. The attachment is fixed to the loader boom by using the quick attach plate and the counterpart on the attachment. If the attachment is not locked to the loader, it may detach from the loader and cause hazardous situations. In the worst case, the attachment may slide onto the driver along a raised boom. For this reason, the attachment must not be raised over one metre under any circumstance if it has not been locked. To prevent hazardous situations, always follow the attachment coupling instructions provided in the following pages. Also remember the safety instructions and additional information shown in the operator's manual of the loader. The attachment is mounted to the loader as follows:



Make sure that an unlocked attachment will not move or fall over. Mount the attachment only on level surface.

1. Step:

- Lift the quick attach plate locking pin / locking pins up and turn them backwards into the slot so that they are locked in the upper position.
- If your loader is equipped with a hydraulic attachment locking system, see additional instructions about the use of the locking system from the relevant manuals.
- Ensure that the hydraulic hoses or electric cables are not in the way during installation

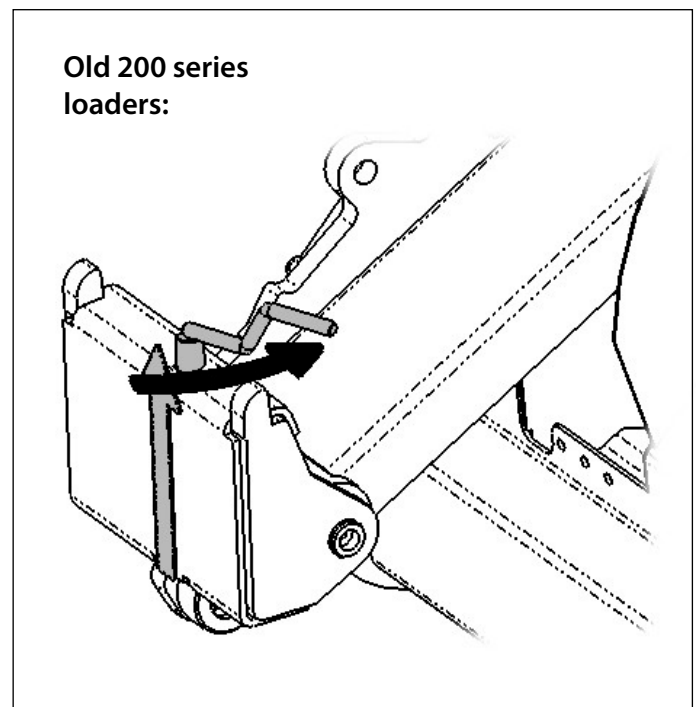
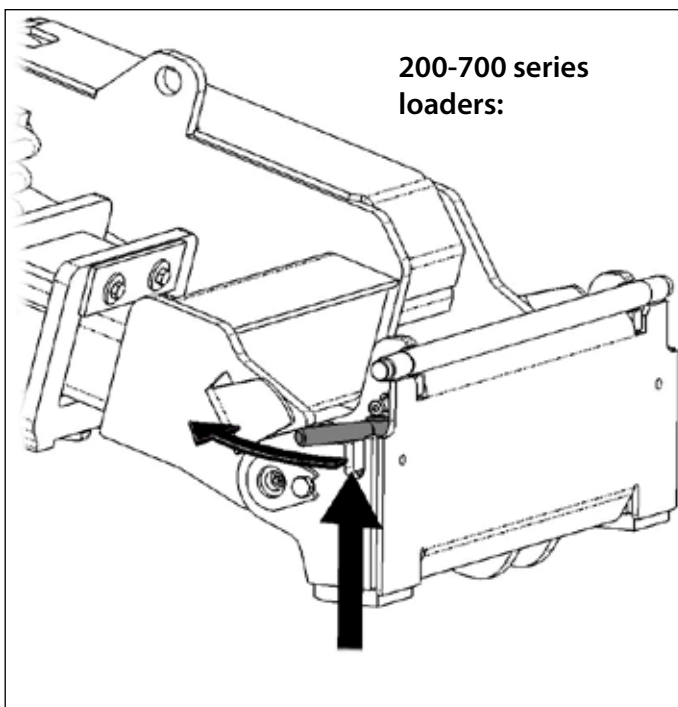

2. Step:

- Turn the quick attach plate hydraulically to an obliquely forward position.
- Drive the loader onto the attachment. If your loader is equipped with a telescopic boom, you can utilise this. Align the upper pins of the loader's quick coupling plate so that they are under the corresponding brackets of the attachment.

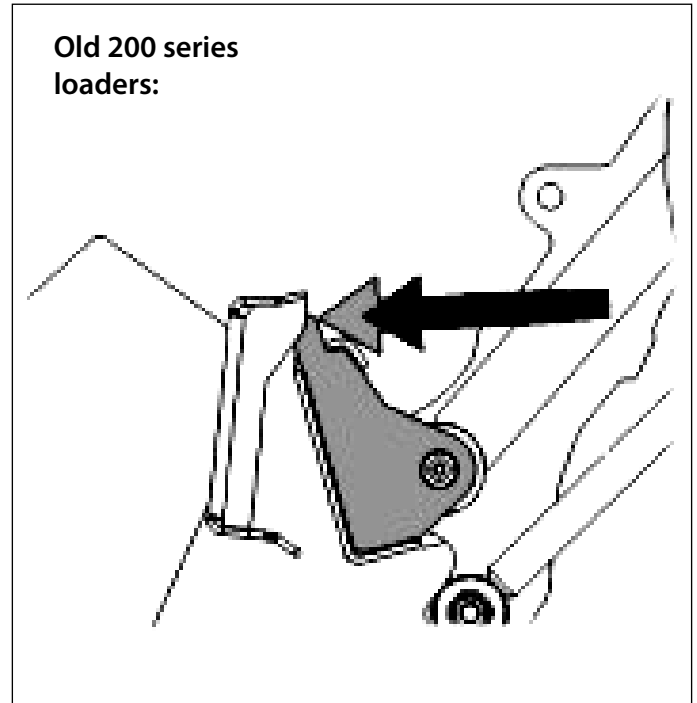
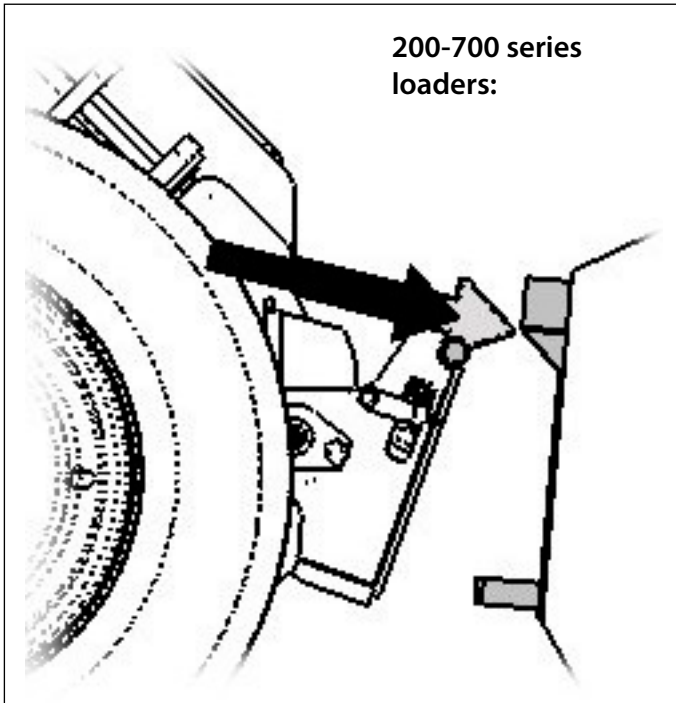

3. Step:

- Lift the boom slightly – pull the boom control lever backward to raise the attachment off the ground.
- Turn the boom control lever left to turn the bottom section of the quick attach plate onto the attachment.
- Lock the locking pins manually or lock the hydraulic locking.
- Always check the locking of pin / pins.

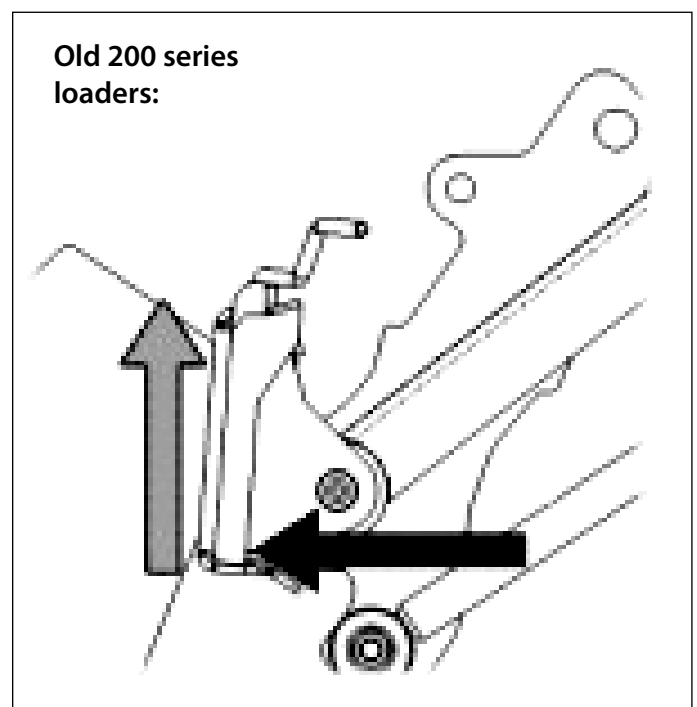
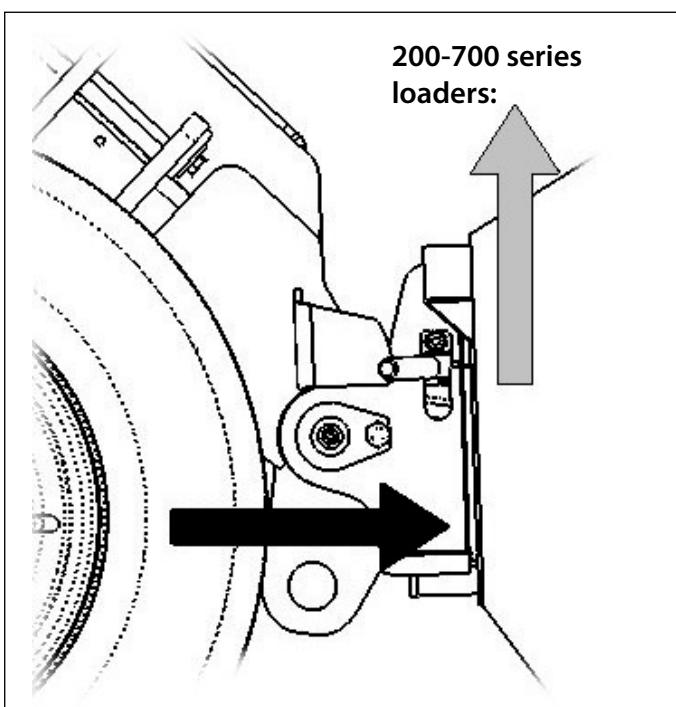



An attachment that has not been completely locked to the loader may fall on the boom or operator, or under the loader during driving, and cause serious injuries or loss of control of the loader. Before moving or lifting the attachment, make sure that the locking pins are in the lower position and come through the fasteners on both sides. Never move or lift an attachment that has not been locked.

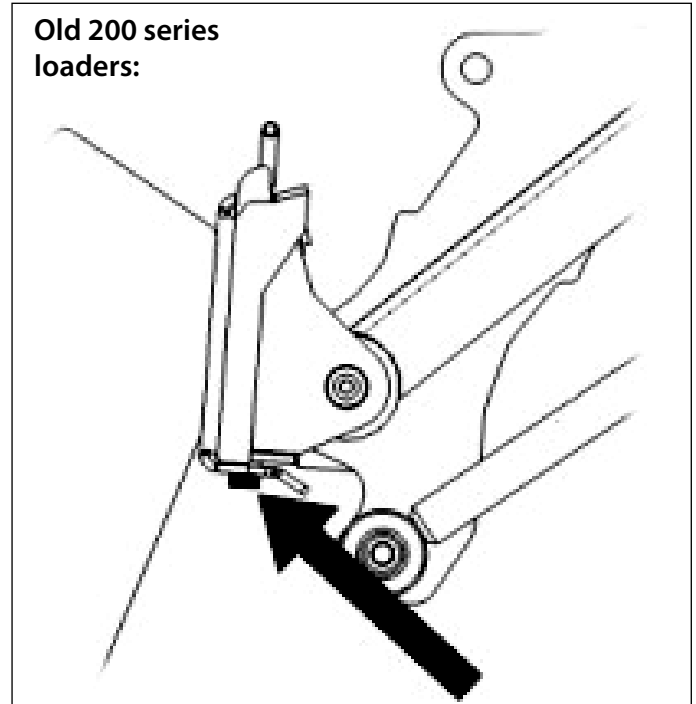
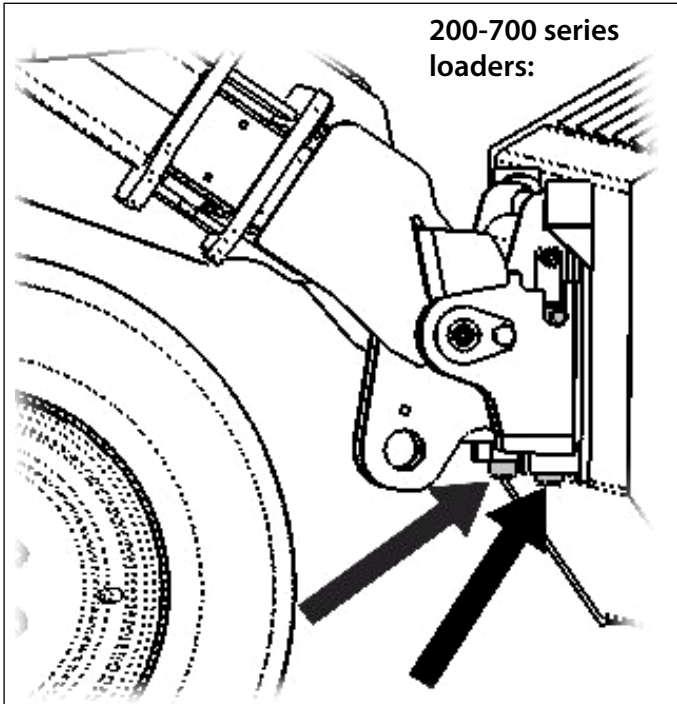

Excessive tilting or lifting of an unlocked attachment increases the risk of tipping the attachment over. Do not use the automatic locking of the locking pins when the attachment is lifted more than one meter from the ground. If the locking pins do not return to the normal position when tilting, do not tilt or raise the attachment any more. Lower the attachment on the ground and secure the locking manually.

CONNECTING AND DISCONNECTING HYDRAULIC HOSES

On 200-700 series loaders hydraulic hoses are connected using the multiconnector system. If you want to change the type of the hydraulic couplings, contact your Avant dealer or service point for instructions or installation services. On old 200-series loaders only conventional quick couplings are available.



Never connect or disconnect quick couplings or other hydraulic components while the system is under pressure or if the control lever of the auxiliary hydraulics control lever is locked on. Connecting or disconnecting the hydraulic couplings while the system is pressurized may lead to unintended movements of the attachment, or ejection of high-pressure fluid, which can cause serious injuries or burns. Follow safe stopping procedure before disconnecting the hydraulic hoses.



Keep the fittings as clean as possible; use the protective caps for the quick couplings on both the attachment and the loader. Dirt, ice, etc. may make using the fittings significantly more difficult. Never leave the hoses hanging on the ground; place them on the holder on the attachment.

CONNECTING THE MULTICONNECTOR SYSTEM:

Align the pins of the attachment connector with corresponding holes of the loader connector. The multiconnector will not connect if the attachment connector is upside down. Connect and lock the multiconnector by turning the lever towards the loader.

The lever should move easily all the way to its locking position. If the lever does not slide smoothly, check the alignment and position of the connector and clean the connectors. Also shut down the loader and release the residual hydraulic pressure. To disconnect the multi connector system switch off the auxiliary hydraulics of the loader and unlock the multiconnector. To unlock the multiconnector, push and hold the unlock button on the side of the multiconnector, then turn the lever to disconnect the connector.

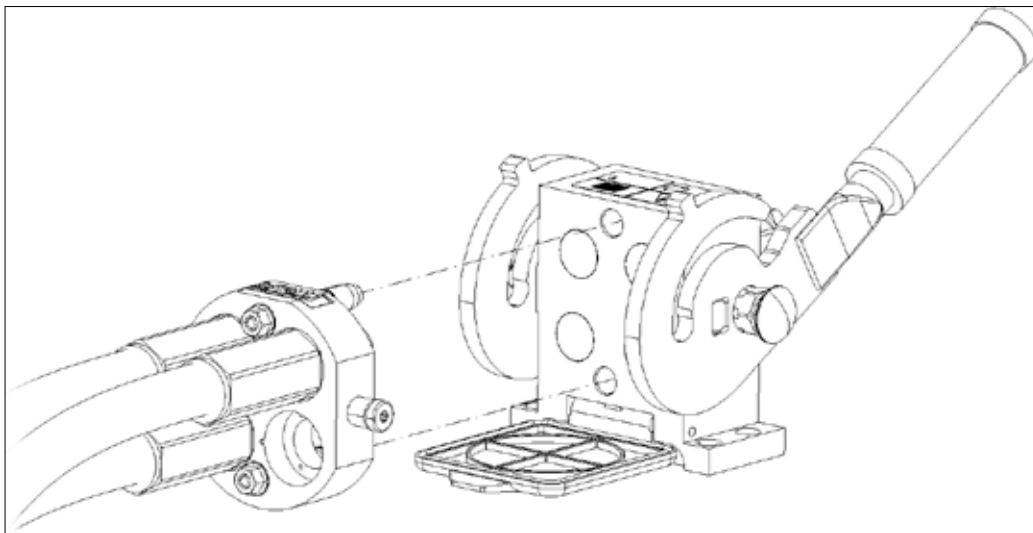

USING CONVENTIONAL QUICK COUPLINGS (alternative couplings for some loader models):

Before connecting or disconnecting the standard quick couplings, the residual pressure must be released as shown below. The conventional quick couplings will not connect, if there is pressure in the hydraulic system.

To connect and disconnect the standard couplings, move the collar at the end of the female fitting. The hoses should be connected so that the fitting equipped with a coloured cap is connected to the corresponding fitting of the loader. Note that the protective caps on the loader and the attachment can be fastened to each other during operation to reduce the accumulation of dirt. When disconnecting the standard quick couplings a small amount of oil may drip from the couplings. Wear protective gloves and have some cloth at hand to keep the equipment clean.



Make sure that all three quick coupling fittings are properly connected, otherwise the hydraulic motor of the attachment may get damaged.

HYDRAULIC COUPLINGS ON OLD 200 SERIES LOADERS

In a old 200-series machine, the hose can be connected by pushing the fitting in the counterpart. When connecting and disconnecting the 200-series hydraulics quick couplings, you should pay attention to their locking. There is a small groove in the collar of all female fittings, and a small ball near the collar. When connecting or disconnecting, the groove and ball must be aligned. The locking prevents the female and male fittings from being disconnected from each other by accident when the attachment moves. The collar may also turn accidentally to the locking position, making it impossible to connect or disconnect the couplings.

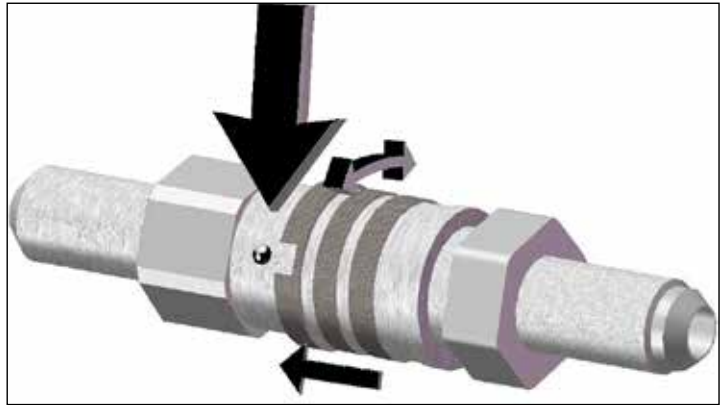

DISCONNECTING THE HYDRAULICS

Before disconnecting the fittings, place the attachment on solid and level surface and release the residual hydraulic pressure.



When uncoupling the attachment from the loader, always disconnect the hydraulic fittings first before unlocking the quick attach plate, to prevent hose damage and any oil spills. Reinstall the protective caps on the fittings to prevent dirt from entering the hydraulic system.

RELEASING RESIDUAL HYDRAULIC PRESSURE

In case residual pressure is left in the hydraulic system of the attachment, it is often possible to disconnect the hydraulic couplings, but it may be difficult to connect them the next time. If the fittings will not connect, the residual pressure must be released by turning the auxiliary hydraulics control lever of the loader, when the engine is turned off. To make sure that there will not be residual pressure in the hydraulic system of the attachment, shut down the loader engine and move the auxiliary hydraulics control lever of the loader back and forth before disconnecting the couplings.

STARTING THE CHIPPER



Start the machine only after it has been set to working position and work can be started. Always turn off the auxiliary hydraulics when the attachment is not in use. Do not leave the machine unattended when the engine of the loader is running. Follow safe stopping procedure always when reaching into the feeding chute is necessary i.e. during cleaning or maintenance.

- Make sure that the chipper is placed firmly on the ground and that the parking brake of the loader is engaged to prevent moving of the equipment during use. Prevent others from operating the controls of the loader while using the chipper.
- To start the log cutter/splitter, turn the auxiliary hydraulics lever on the loader to its locked position and set moderate engine rpm, depending on the working pace. Depending on the loader model, two hydraulic pumps may be used to reduce engine noise. Do not exceed the maximum permissible input of hydraulic oil; full rpm must not be used when operating with 600 or 700 series loaders.
- Start the chipper slowly and gradually increase the engine until the hydraulic flow is within the recommended range depending on the chipping operation. CAUTION! Never exceed the maximum allowable operating speed of the chipper.
- The chipper is now ready to be used.



IMPORTANT! When the chipper is driven with the hydraulic system, it is extremely important to slow the loader engine speed to idle before switching off the auxiliary hydraulics of the loader.

SAFE STOPPING PROCEDURE

- Safe stopping of the attachment, before opening any guard or cover, or reaching towards the blades:
- Stop the attachment by turning the control bar of the chipper to stop position and switch off the auxiliary hydraulics of the loader.
- Make sure that the attachment is lowered firmly on the ground and that the attachment remains stable.
- Shut down the loader engine and engage the parking brake.
- Release the residual pressure of the hydraulic system by moving the auxiliary hydraulics control lever to its extreme positions.
- Remove the ignition key and ensure that others can't operate the controls of the loader.



When stopping the chipper, the knife disk continues rotating like a flywheel even after the hydraulic flow has been switched off. Please wait until the disk has stopped completely before performing any further actions.

The chipper requires approx. 1 ½ minutes to slow down from maximum speed to complete stop (1000 rpm -> 0 rpm).

CHIPPING



During chipping, please observe the following safety instructions:

- The danger zone of the chipper is approx. 20 m.
- During operation, the danger zone must be safeguarded to prevent unauthorized people from entering the danger zone. If necessary, operation must be interrupted.
- The operator of a chipper with manual feed must wear the following personal protective equipment: safety helmet, ear protection, protective goggles, cut resistant safety boots and required protective clothing.
- Never work in front of the feed hopper. Stand on the left side of the feed hopper when feeding, since the feed rollers may push the wood upwards or to the right.
- Never hold any part of the body into the feed hopper or into another part of the chipper with the machine running.
- Make sure that loose clothing or long hair cannot be caught by rotating machine parts or by the material to be fed.
- Before feeding in the material to be chipped, ensure that the wood fed into the chipper is free from metal or soil (such as nails, stones, etc.).
- Never feed ropes or barbed wire to the chipper since these could get caught on the operator's body and draw him into the feed hopper.
- Do not use the chipper at temperatures below -20 °C. This is to avoid damage due to brittleness – especially of the knives – caused by the cold.
- Avoid chipping wood that is frozen solid; otherwise, excessive stress will be exerted on the chipper and self-feeding will be impaired.
- FIRE HAZARD! Always keep adequate fire-fighting equipment on hand when using the chipper. Regularly check the surface temperature of the chipper. If the chipper suddenly heats up abnormally, stop the chipper and determine the cause of overheating. Regularly, check the temperature of the bearings. Pay special attention to careful maintenance, and keep the chipper free from dust. If the chipper starts smoking, pour water into the feed hopper.

OPERATION OF CHIPPER AND FEED UNIT

- Start the chipper. Notice! See section "Starting the chipper".
- Set the operating lever to the FEED FORWARD F position. Notice! See picture "Operating lever functions".
- Push the material to be chipped into the feed hopper. Release the material immediately when the feed rollers start to rotate.
- When chipping large trunks or the like, the rotary speed of a low-power tractor often drops during chipping very long wood pieces. Temporarily stop feeding by setting the operating lever to the STOP position. After the rotary speed has sufficiently increased again, continue feeding by setting the operating lever to the FEED FORWARD F position.



Oil will heat when travelling through the hydraulic pump, hydraulic motor and the valves. The heating can be considerable if the loader has a small hydraulic tank. Check the oil temperatures twice an hour to prevent the oil from overheating. If the oil overheats, let it cool down by stopping the chipping.

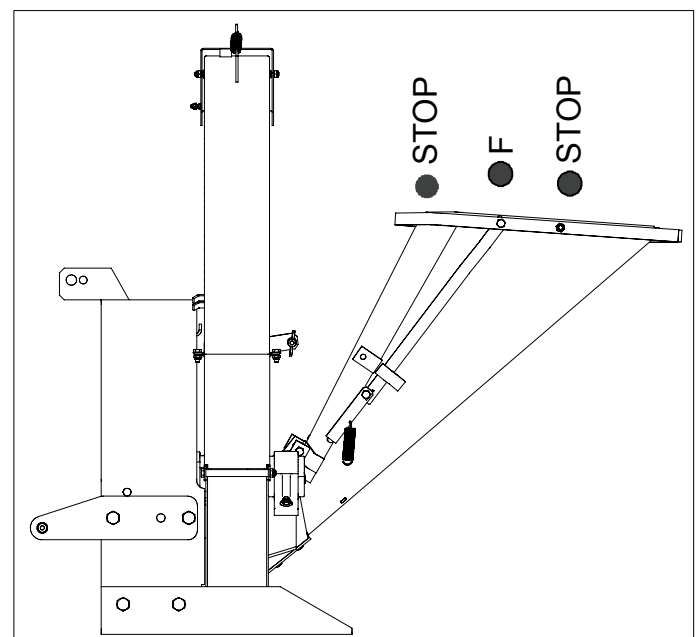

Fig. 5 Operating lever functions

EMPTYING THE CHIPPER AFTER USE

Let the chipper run empty by operating it for a short time.

SWIVELING THE FEED HOPPER TO THE TRANSPORT POSITION

1. Attach the feed hopper to the chipper using an M12x30 hexagon head bolt and an M12 butterfly nut. See the figure showing how the feed hopper is swiveled to the transport position.

STORAGE OF THE CHIPPER

- Before detaching the chipper from the tractor, park it on level and hard ground. Take appropriate measures to prevent the chipper from moving or falling.
- If the chipper is to be stored for a long period, lubricate the knives e.g. with petroleum jelly.
- Take appropriate measures to keep the water drainage holes on the lower chamber open.

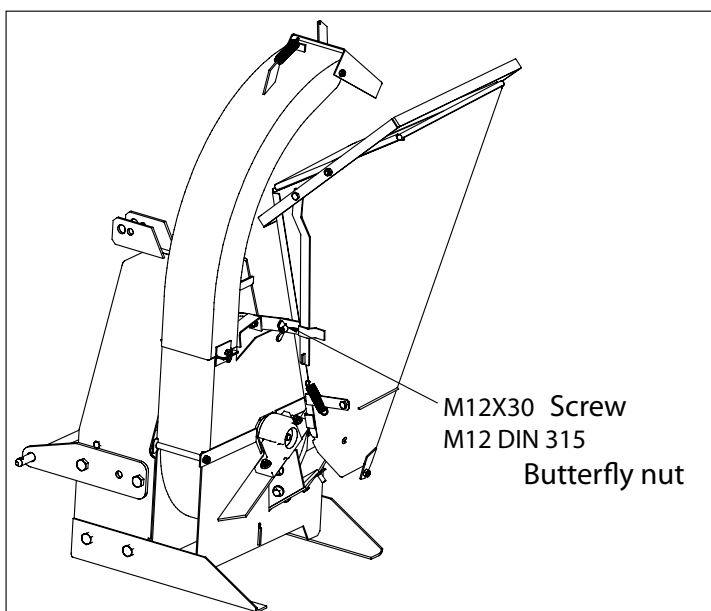

Fig 6. Swiveling the feed hopper to the transport position

MAINTENANCE



Before beginning maintenance and repair

- place the chipper onto level and hard ground and make sure it cannot tip;
- turn off the loader.
- disconnect the hydraulic hoses from the loader.
- familiarize yourself with the machine-specific maintenance and repair instructions.

In case of doubt, please contact the manufacturer.

- Always lock the rotor before adjusting or changing the knives.
- Always wear protective gloves when handling knives.

PERIODIC INSPECTIONS

- With new machines, check the mounting bolts for tightness after the first operating hour, tightening them if necessary. Tightening torques are shown in table.
- Check the mounting bolts for tightness once a week.
- The knife-to-anvil clearance is adjusted to the specified values. For instructions on adjusting the clearance, see Adjusting the knife-to-anvil clearance.

REPLACING THE BEARING

1. Open the upper chamber.
2. Remove the fastening bolts M10 (7) and the upper bearing housings (6).
3. Mark the location of the tightening cone on the shaft.
4. Lift the disk.
5. Bend the claw of the securing ring (3) out from the notch on the axle nut and open the axle nut.
6. Remove the axle nut, securing ring, spacer ring (4), bearing (5), spacer ring (9), and tightening cone (10).
7. Install the tightening cone, spacer ring (9), and bearing on the disk shaft. Note the thickness of the spacer ring (9) - see Fig. 7a.
8. Install the securing ring with the claws facing outwards and the inside claw in the groove of the tightening cone, and install the axle nut.
9. The inner ring of the bearing should press tightly against the tightening cone.
10. Tighten the axle nut with a hook spanner until the bearing is tightly on the cone, or to 80 Nm. However, the outer ring of the bearing should turn freely. Note the location of the tightening cone on the shaft.
11. Bend one claw of the securing ring (3) into a notch on the axle nut.
12. Install the other half of the dust cover and end plate on the bearing housing. Install the spacer ring (4) on the shaft.
13. Lower the disk to the bearing housing.
14. Attach the other half of the dust cover to the upper bearing housing; install the upper bearing housing fastening bolts and tighten to 50 Nm.
15. Lubricate the bearing housing. An excessive amount of grease causes overheating and impairs lubrication.

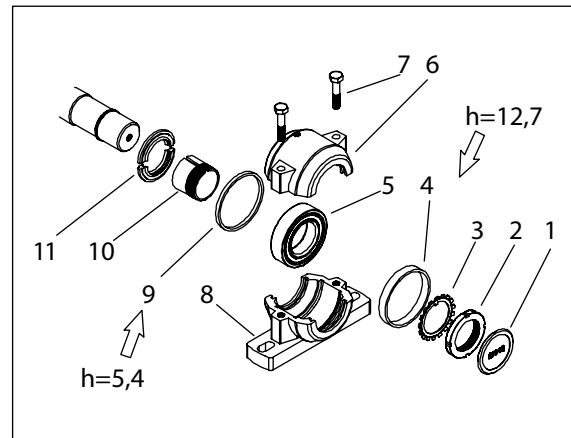

Fig. 7a. Bearing, feeder side

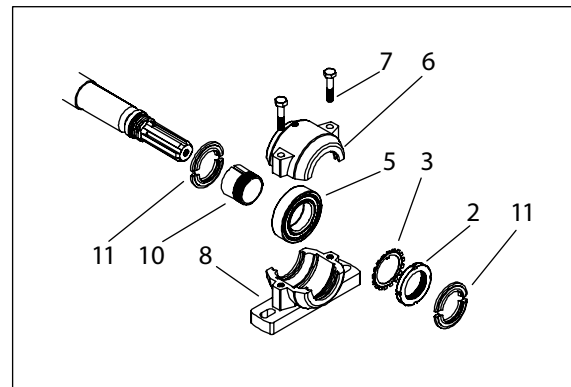

Fig. 7b. Bearing, splined shaft side

The bearings at the feeder side and splined shaft side are different from each other. The bearing at the splined shaft side, Fig. 7b., does not have spacer rings (4 and 9) and an end plate (1). The bearing at the splined shaft side has dust covers on both sides (11).

ADJUSTING THE BEARING CLEARANCE

1. Open the upper chamber.
2. Remove the fastening bolts M10 (7) and the upper bearing housings (6).
3. Remove the grease from the bearing housing.
4. Lift the disk.
5. Bend the claw of the securing ring (3) out from the notch on the axle nut and open the axle nut.
6. Remove the spacer ring (3) if the bearing is at the feeder side.
7. Measure the radial clearance on top of the bearing between the rollers and outer ring with a feeler gauge. The clearance should be 0.02–0.03 mm (0,008-0,012"). Measure the clearance by pushing the feeler gauge between the rollers (point A, Fig. 8b.) through the bearing and then moving the gauge back and forth between the rollers and outer ring - see Fig. 8c. Do not force the feeler gauge through the clearance.
8. If the clearance exceeds 0.03 mm, bend the claw of the securing ring (2) out from the notch on the axle nut (1).
9. The bearing is tightened by turning the axle nut clockwise with a 70 mm (2 3/4") hook spanner until the right clearance is achieved. Do not tighten by hammering the axle nut.
10. Turn the axle nut clockwise until the notch is aligned with the nearest claw of the securing ring. Bend the claw into the notch. Do not bend the claw that was bent earlier.
11. Lower the disk to the bearing housing.
12. Install the upper bearing housing and tighten the bolts (6) to 50 Nm (36 7/8 lbf).
13. Lubricate the bearing housing. An excessive amount of grease causes overheating and impairs lubrication.

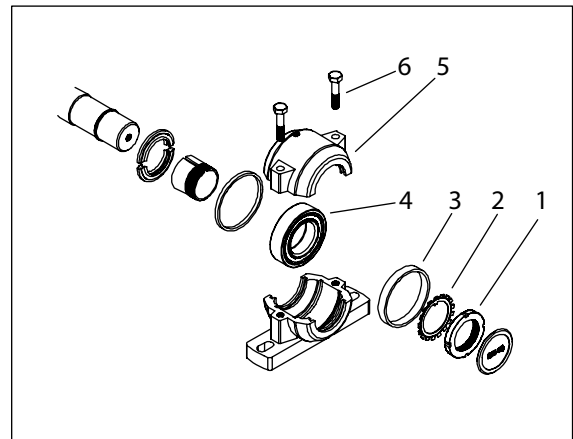

Fig. 8a. Bearing, feeder side

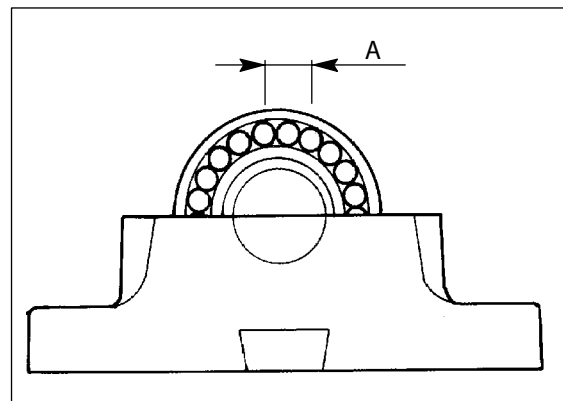

Fig. 7b. Push the feeler gauge between the rollers and outer ring.

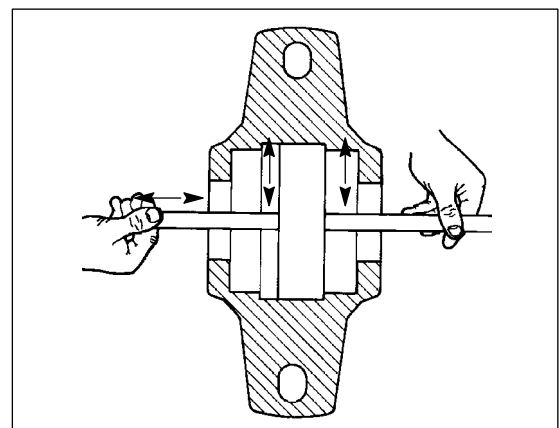

Fig. 8c. Measuring the clearance

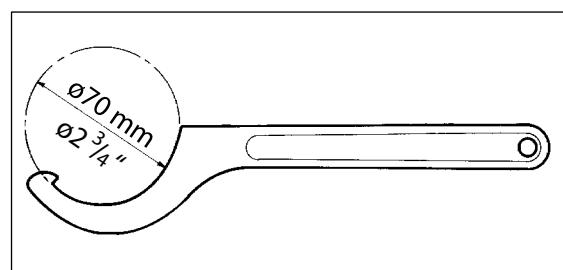

Fig. 8d. Tightening the bearing

LUBRICATING THE BEARINGS

- The bearings are lubricated at the factory, and a similar lubricant should be used for subsequent lubrication (Shell Alvania Grease R 3. or Kendall L427). An excessive amount of grease causes overheating and impairs lubrication.
 - Lubricate the bearings every 200 working hours or at least once a year.
1. Open the upper bearing housing - see bearing housing assembly drawing, (pic. 7a). Remove old grease as carefully as possible and replace it with new grease. Do not fill the bearing housing with grease.
 2. Install the upper bearing housing and tighten to 50 Nm.

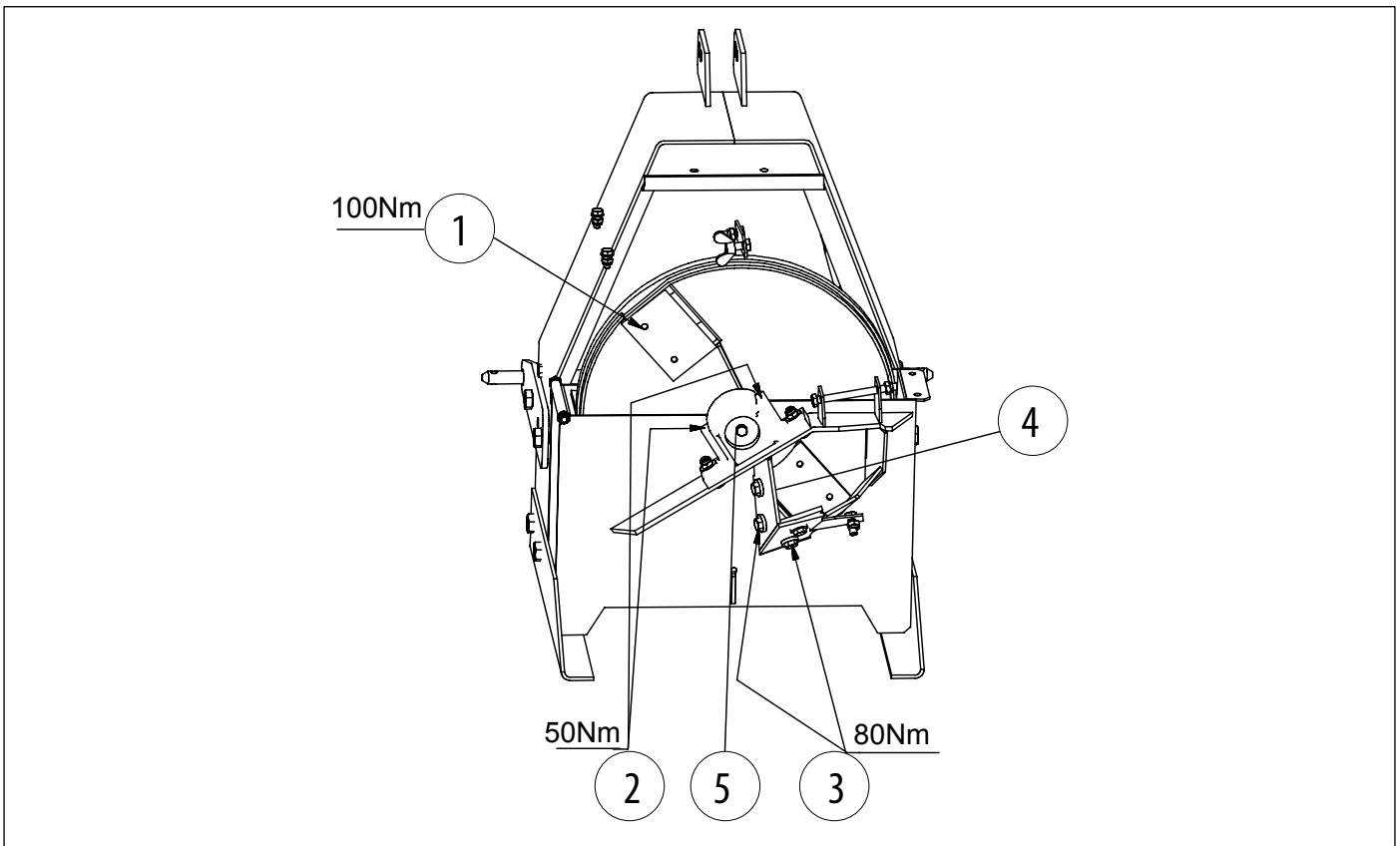

Fig 10. Checklist for tightening and checking clearances

| Item | Width across flats, mm (inches) | Tightening torque, Nm (lbf) |
|---|---------------------------------|----------------------------------|
| 1. Check the knife bolts for tightness. | 19 (12/16") | 100 (73 11/16) |
| 2. Check the bearing housing bolts for tightness on both sides. | 17 (11/16") | 50 (36 7/8) |
| 3. Check the anvil bolts for tightness. | 19 (12/16") | 80 (58 15/16) |
| 4. Check the clearance between knives and vertical anvils. | 19 (3/4") | 1,2 - 1,5 mm (0,02 - 0,06") |
| 5. Check the bearings for radial clearance. | | 0,02 - 0,03 mm (0,008 - 0,0012") |

KNIFE AND ANVIL MAINTENANCE



Read the safety instructions. The disk continues rotating like a flywheel after the hydraulic power is disengaged. Please wait until the disk has stopped completely before performing any further actions.



When manually turning the rotor, never touch the edges of the lower chamber or other parts where there is the risk for the hands to get squeezed between the lower chamber and the rotor knives or blades.

REMOVING THE KNIVES

1. Remove the knife fastening bolts (M12). Turn the wrench in such a way that your hands would not hit the knife if the wrench should slip. Fig 12.



Wear protective gloves when handling knives or anvils.

OPENING AND REMOVING THE UPPER CHAMBER

- Remove the M10 mounting bolts of the upper chamber. Swing the upper chamber to the side.
- Remove the M12 pin to release the upper chamber.



Exercise extreme caution when opening the upper chamber. Take appropriate measures to keep the upper chamber from falling down.

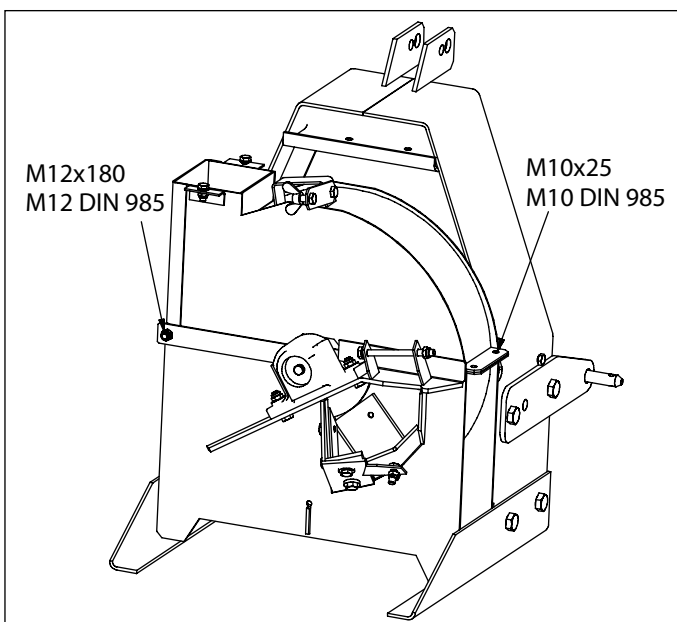

Fig 11. Removing the upper chamber

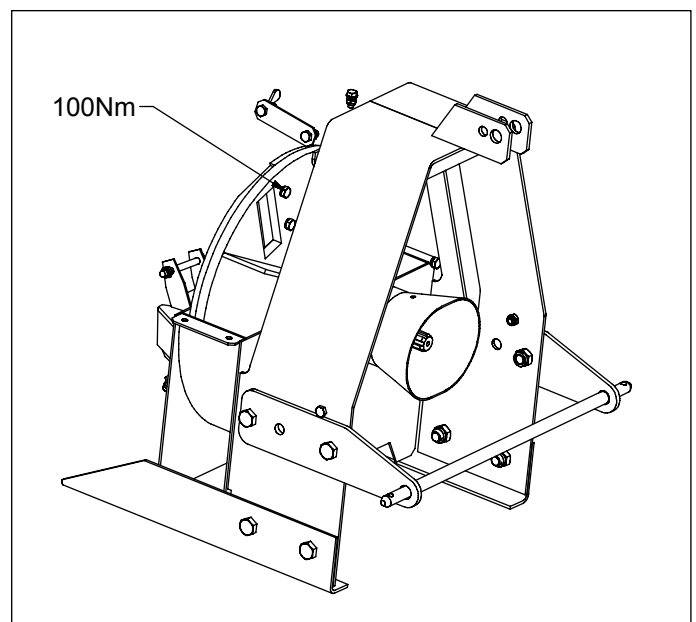

Fig 12. Removing the knife fastening bolts

SHARPENING THE KNIVES



Sharpen all knives equally. This ensures disk balance. Avoid heating the knife during sharpening.

The knives need sharpening when

- the self-feeding of wood has decreased;
- the power demand has increased;
- the chip surface is rough.
- The individual chips have become smaller.

Normally, the knives can be sharpened several times without actually being removed (with, e.g., a sharpening stone or belt grinder).

More thorough conditioning is carried out with a surface grinder, with the knives removed.

The grinding angle of the knives is 32° and their honing angle 45°. The honing angle is intended to prevent edge breakage. Fig 13.

The hone angle is ground to a 45° angle with two to three longitudinal strokes, using a level sharpening stone.

Any burrs can be removed by parallel grinding of the surface opposite to the knife mounting bolts. Fig 15.

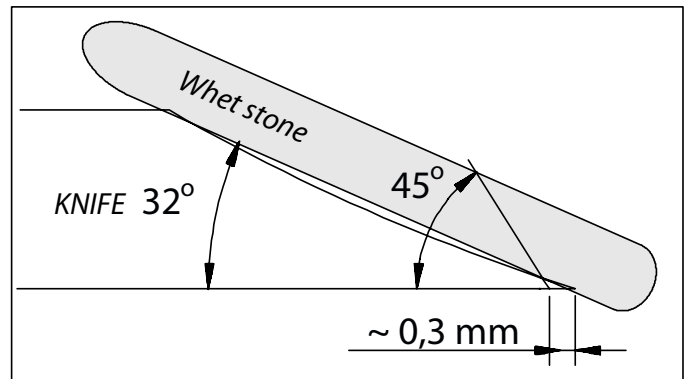

Fig 13. The profile of a concave knife

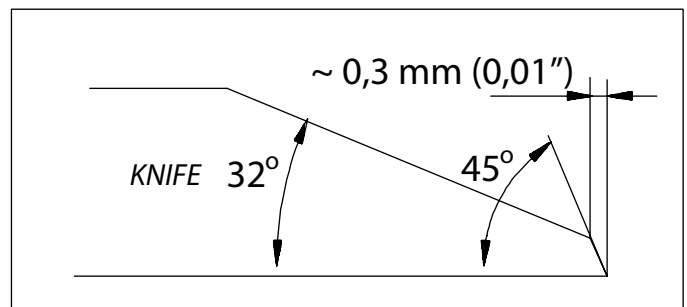

Fig 14. A knife with a flat profile

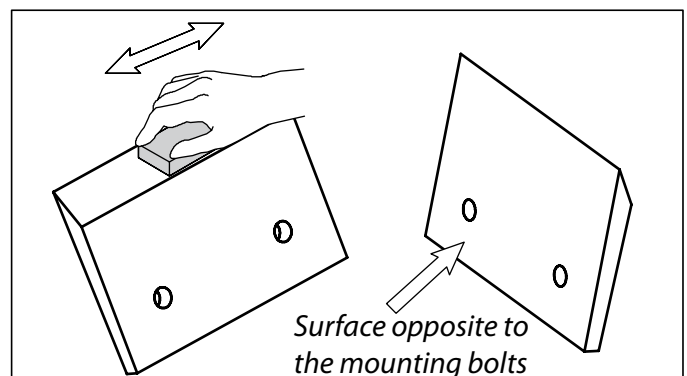

Fig 15. Final grinding of the knife

REMOVING THE ANVILS

The chipper features both a vertical and horizontal anvil. To remove the anvils, open the fastening bolts (A) and (B) (M12). The horizontal anvil fastening bolt (B) is located below the feed opening. Fig 16.

SHARPENING THE ANVILS

If you notice wear or rounding of the inner edge of the anvil, sharpen the anvils so that the original angles are retained. Fig 17.

INSTALLING THE KNIVES AND ANVILS

- Check the condition of the fastening bolts and nuts.
- Install the knives and anvils and tighten the fastening bolts to the torques specified in table.
- Adjust the knife-to-anvil clearance.

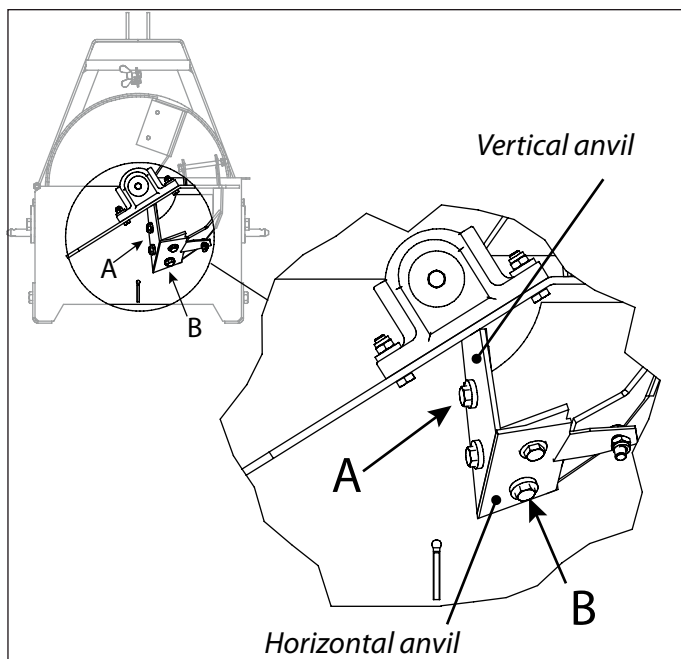

Fig 16. Anvil fastening bolts

ADJUSTING AND CHECKING THE KNIFE-TO-ANVIL CLEARANCE

The need for adjusting the anvils is determined by the amount the knives are sharpened. Always check and, if necessary, adjust the clearance between knives and anvils

- after a heavy sharpening;
- if the knives were removed - for example, due to sharpening;
- if new knives are replaced,
- if chip length is adjusted.

Check the clearance with a feeler gauge.

1. Loosen the M12 locking screws (A) and (B) of the anvils. Fig 18.
2. Turn the cutting disk in such a way that the front edge of the knife is exactly opposite the vertical anvil. Slide a feeler gauge between the knives.
3. Tighten the screws of the anvil (A).
4. Adjust the play of the horizontal anvil towards the front edge of the knife to 1.2-1.5 mm.
5. Tighten the locking screw (B).
6. Recheck the knife play.

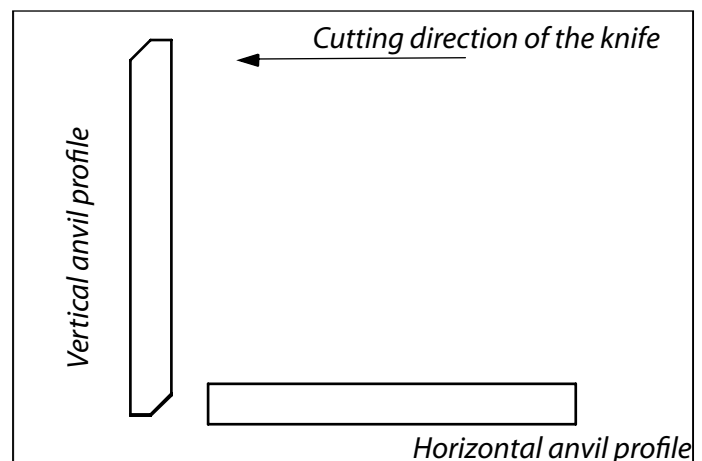

Fig 17. Anvil profiles

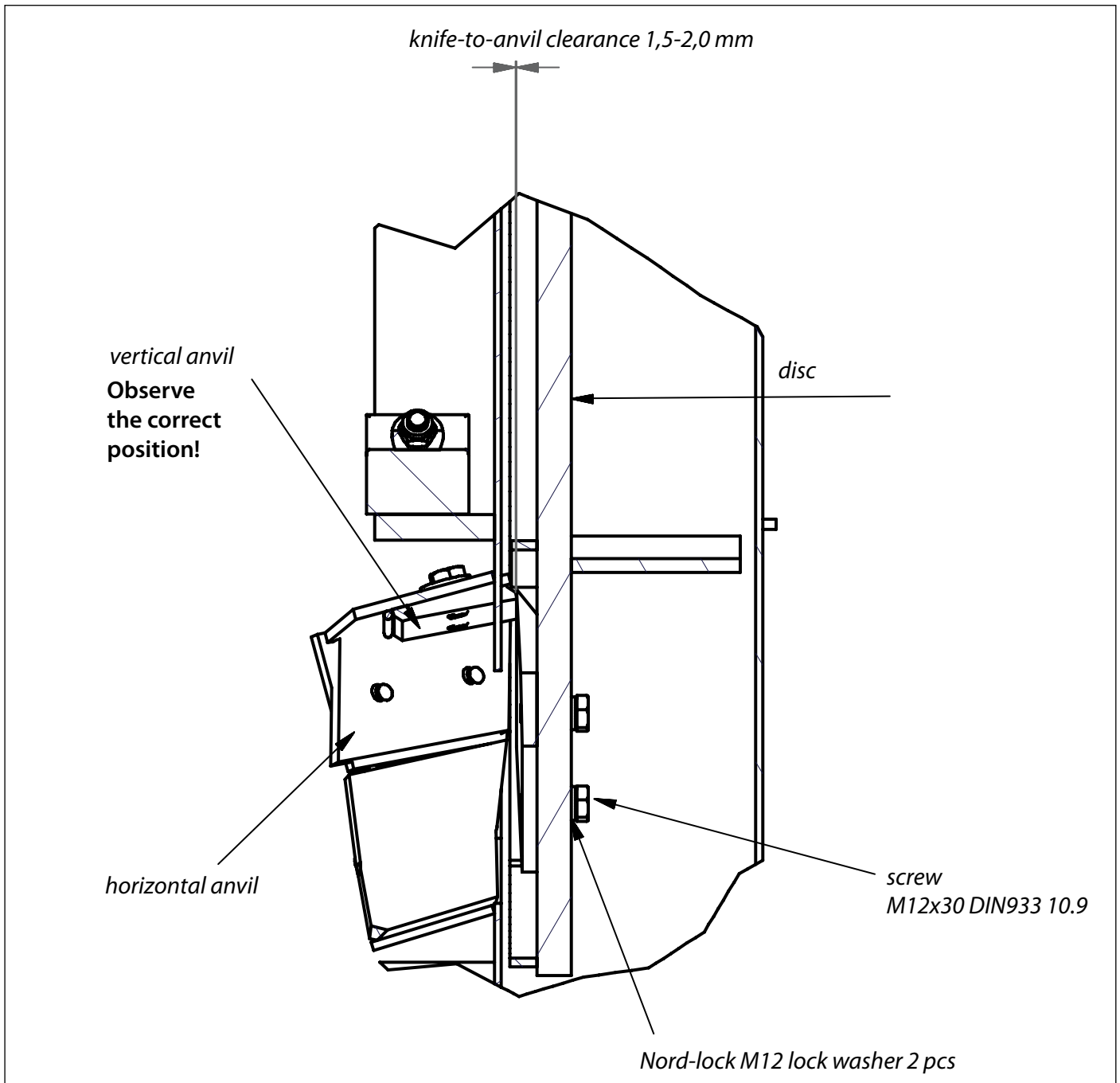
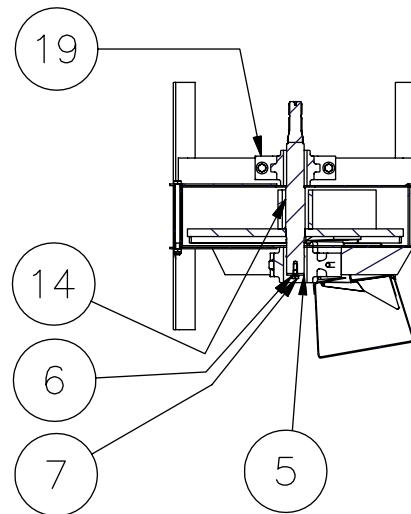
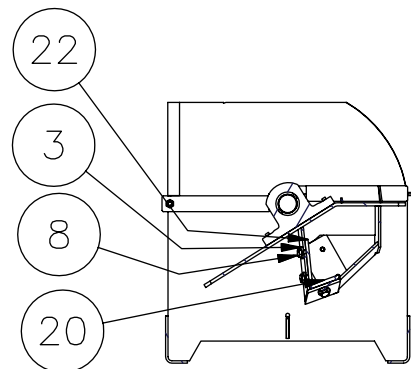
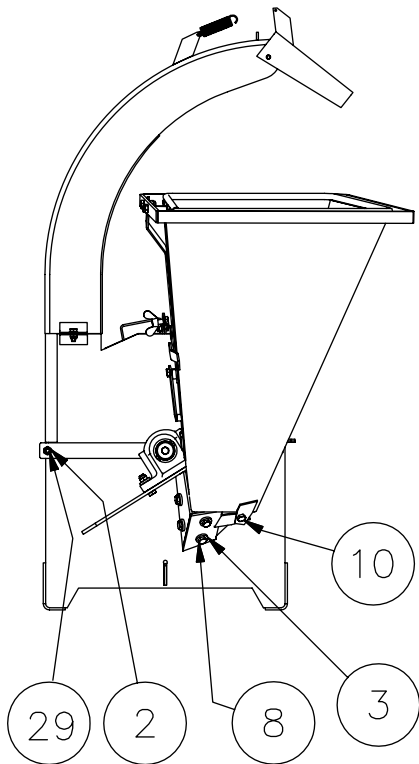
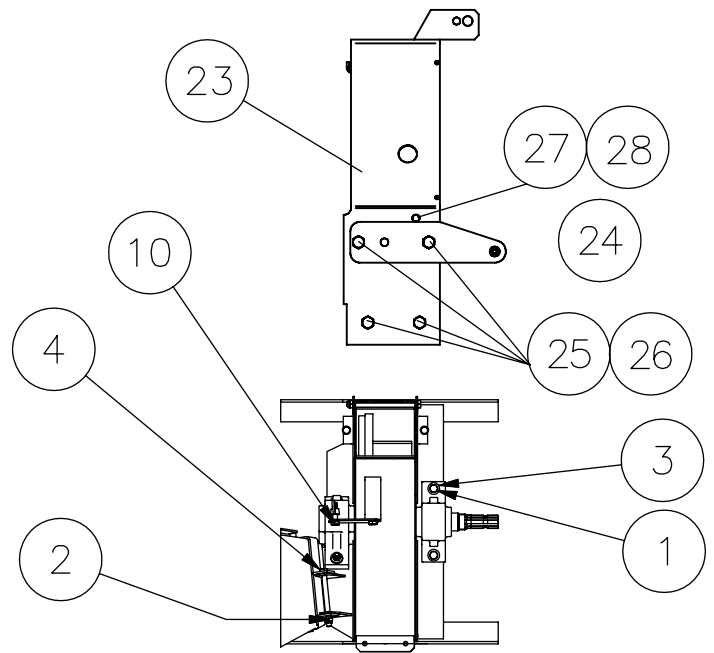
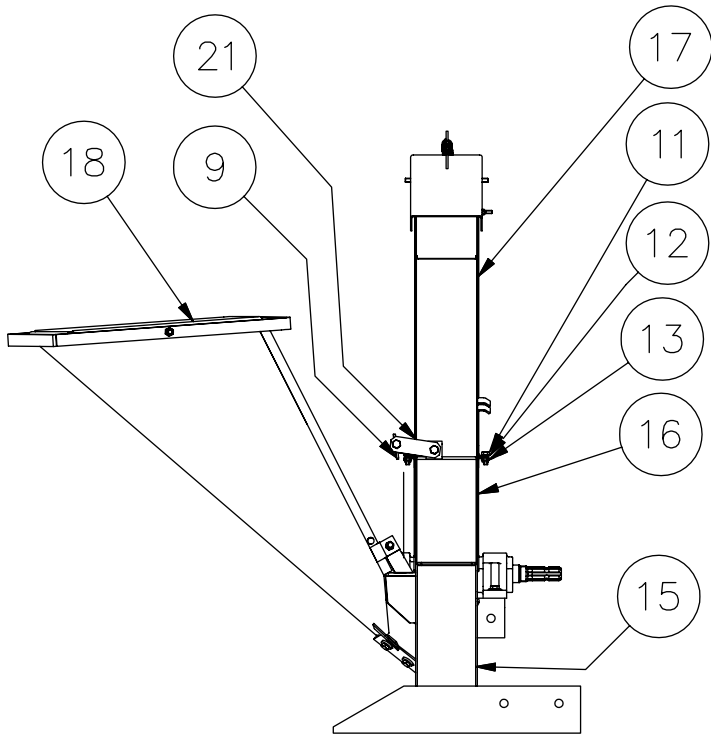

Fig 18. Cross-section of the disk and knives / anvils

CH100 CHIPPER



CH100 CHIPPER

| Part | Order no | Description | Remarks | Qty |
|------|----------|-----------------------|---------------------|-----|
| 1 | 52062041 | Screw | M12X50 DIN933 88ZN | 4 |
| 2 | 52117124 | Lock nut | M12 DIN985 8ZN | 7 |
| 3 | 52200490 | Washer | M12 DIN 7349 ZN | 8 |
| 4 | 52062502 | Screw | M12X120 DIN931 88ZN | 1 |
| 5 | 43340934 | End plate | | 1 |
| 6 | 52211042 | Spring washer | M10 DIN127 ZN | 1 |
| 7 | 52060209 | Screw | M10X16 DIN933 88ZN | 1 |
| 8 | 52062015 | Screw | M12X20 DIN933 88ZN | 4 |
| 9 | 52117900 | Butterfly nut | M12 | 1 |
| 10 | 52062023 | Screw | M12X30 DIN933 88ZN | 2 |
| 11 | 52060225 | Screw | M10X25 DIN933 88ZN | 2 |
| 12 | 52200045 | Washer | M10 DIN125 58ZN | 2 |
| 13 | 52117108 | Lock nut | M10 DIN985 8ZN | 2 |
| 14 | 33620100 | Disc | | 1 |
| 15 | 33620250 | Lower chamber | | 1 |
| 16 | 33620350 | Upper chamber | | 1 |
| 17 | 33620400 | Discharge pipe | | 1 |
| 18 | 33620650 | Drop spout | | 1 |
| 19 | 43620660 | Bearing system | | 2 |
| 20 | 43620670 | Anvil | | 1 |
| 21 | 43620690 | Support for transport | | 1 |
| 22 | 43620700 | Side anvil | | 1 |
| 23 | 33620850 | Mounting frame | | 1 |
| 24 | 43343790 | Drawbar | | 1 |
| 25 | 52062213 | Screw | M20X40 DIN933 88ZN | 8 |
| 26 | 52117207 | Lock nut | M20 DIN985 8ZN | 8 |
| 27 | 52062015 | Screw | M12X20 DIN933 88ZN | 2 |
| 28 | 52117124 | Lock nut | M12 DIN985 8ZN | 2 |
| 29 | 52062486 | Screw | M12x180 DIN931 88ZN | 1 |

DISC, COMPLETE

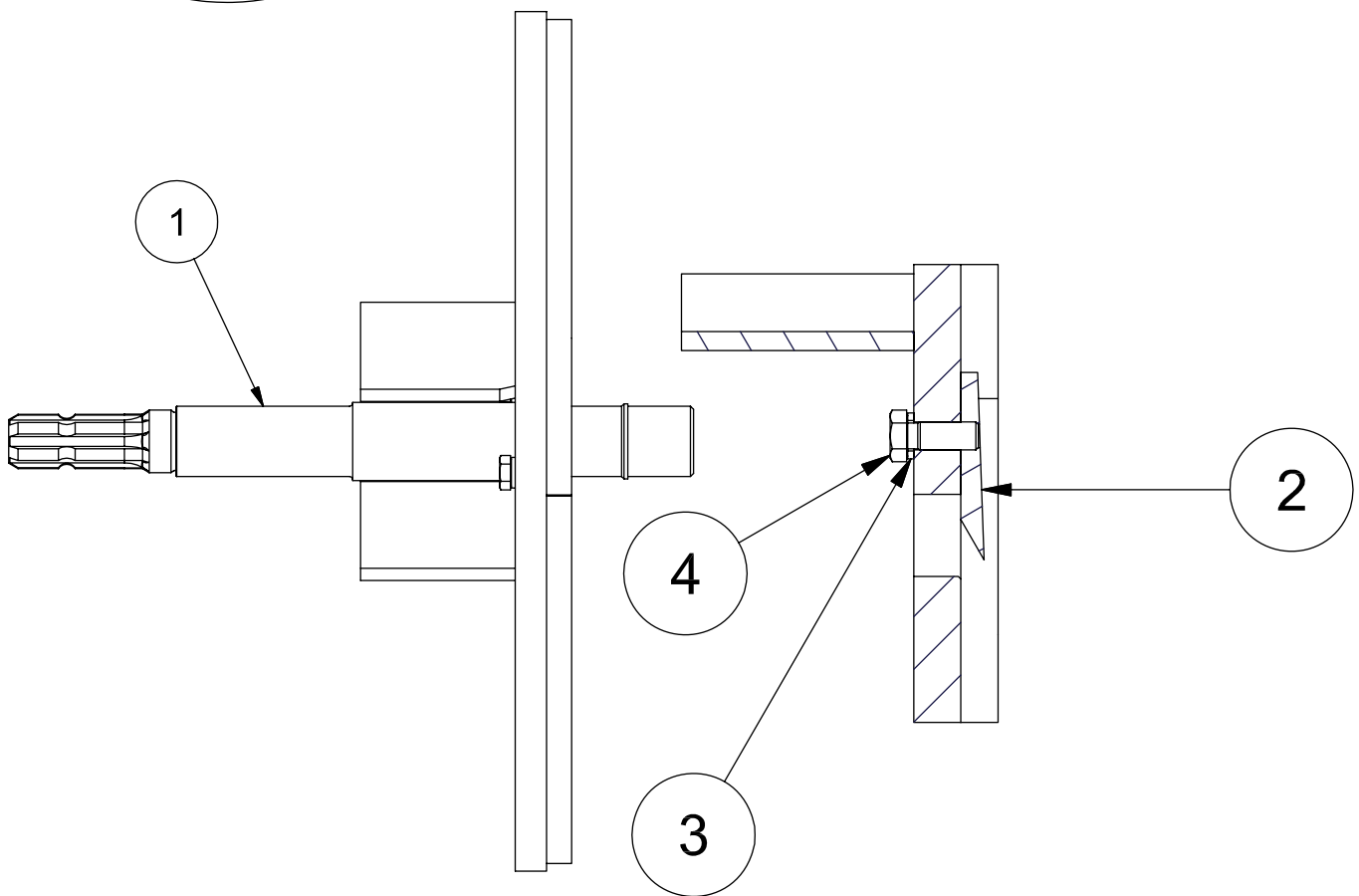
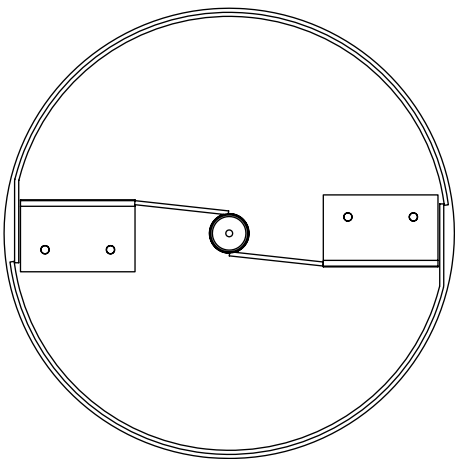

| Part | Order no | Description | Remarks | Qty |
|------|----------|-------------|----------------------|-----|
| 1 | 33620070 | Disc | | 1 |
| 2 | 43620080 | Knife | | 2 |
| 3 | 52214269 | Lock washer | M12 NORD-LOCK | 4 |
| 4 | 52091839 | Screw | M12x30 DIN933 10.9ZN | 4 |

BEARING SYSTEM

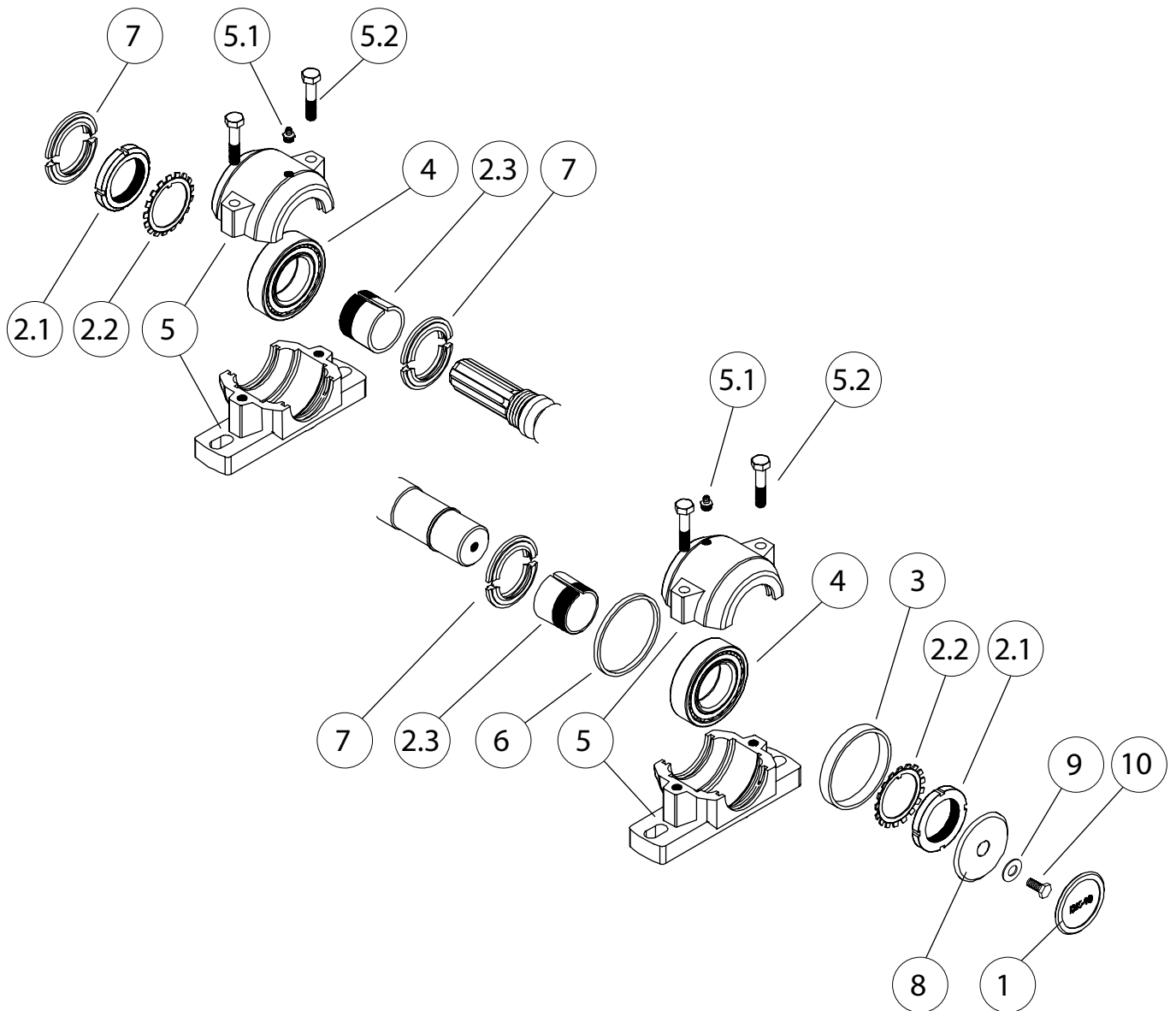

| Part | Order no | Description | Remarks | Qty |
|------|----------|------------------------|---------------------|-----|
| 1 | 54513569 | Dust cover | | 1 |
| 2 | 54512371 | Tightener sleeve | complete | 2 |
| 2.1 | - | Axle nut | | 1 |
| 2.2 | - | Locking plate | | 1 |
| 2.3 | - | Tightener sleeve | | 1 |
| 3 | 43513360 | Spacer ring | D90/83X12.7 | 1 |
| 4 | 54512363 | Tapered roller bearing | | 2 |
| 5 | 54513590 | Bearing housing | | 2 |
| 5.1 | 52401015 | Grease nipple | AR1/8 | 1 |
| 5.2 | - | Screw | M10x50 DIN 931 10.9 | 2 |
| 6 | 43513350 | Spacer ring | D90/83X5.4 | 1 |
| 7 | 52334232 | Seal | | 1 |
| 8 | 43340934 | End plate | | 1 |
| 9 | 52214251 | Lock washer | M10 NORD-LOCK | 1 |
| 10 | 52060928 | Screw | M10X20 DIN933 88 | 1 |

BELT TRANSMISSION CH100 i=2,0

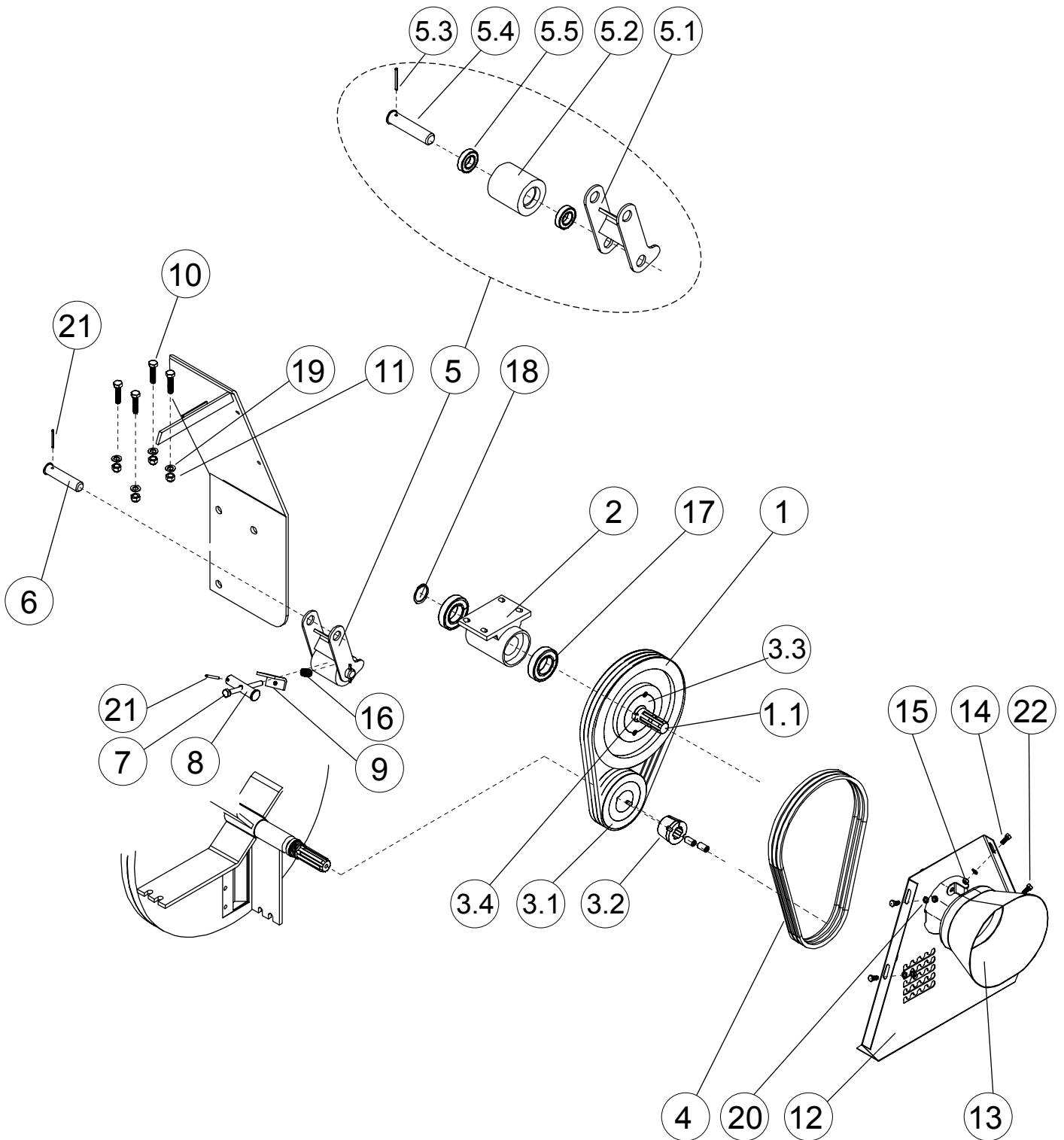

BELT TRANSMISSION CH100 i=2,0

| Part | Order no | Description | Remarks | Qty |
|------|----------|------------------------------|--------------------|-----|
| 1 | 53220570 | Belt pulley | D315 | 1 |
| 1.1 | 43621220 | Splined shaft | | 1 |
| 2 | 43514450 | Bearing housing | | 1 |
| 3.1 | 53220590 | Belt pulley | D150 | 1 |
| 3.2 | 53220580 | Tapered adapter sleeve | | 1 |
| 3.3 | 53220560 | Taper bushing | | 1 |
| 3.4 | 43341437 | Pile | | 1 |
| 4 | 54822382 | Belt | | 3 |
| 5 | 43512020 | Belt tightener | complete | 1 |
| 5.1 | 43512030 | Belt tightener | | 1 |
| 5.2 | 43341106 | Reel | | 1 |
| 5.3 | 52840055 | Cotter pin | 5X50 DIN1481 | 1 |
| 5.4 | 43341114 | Pin | | 1 |
| 5.5 | 54511134 | Slotted sealed ball bearing | | 2 |
| 6 | 43341114 | Pin | | 1 |
| 7 | 52063658 | Screw | M12X20 DIN933 88ZN | 1 |
| 8 | 43511950 | Pin | | 1 |
| 9 | 43512050 | Adjusting plate | | 1 |
| 10 | 52090560 | Screw | M12x30 DIN933 10.9 | 4 |
| 11 | 52117124 | Lock nut | M12 DIN985 8ZN | 4 |
| 12 | 33621380 | Cover plate | | 1 |
| 13 | 43511780 | Cover of the universal shaft | | 1 |
| 14 | 52060126 | Screw | M12X20 DIN933 88ZN | 4 |
| 15 | 52117082 | Lock nut | M12 DIN985 8ZN | 6 |
| 16 | 43402150 | Spring | | 1 |
| 17 | 54512140 | Ball bearing | | 2 |
| 18 | 52230257 | Circlip | 45x2,5 DIN471 | 1 |
| 19 | 52200466 | Washer | M10 DIN127 ZN | 4 |
| 20 | 52200037 | Washer | M12 DIN985 8ZN | 6 |
| 21 | 52840055 | Cotter pin | 5X50 DIN1481 | 2 |
| 22 | 52021250 | Locking bolt | M12X20 DIN933 88ZN | 2 |

DISCHARGE PIPE

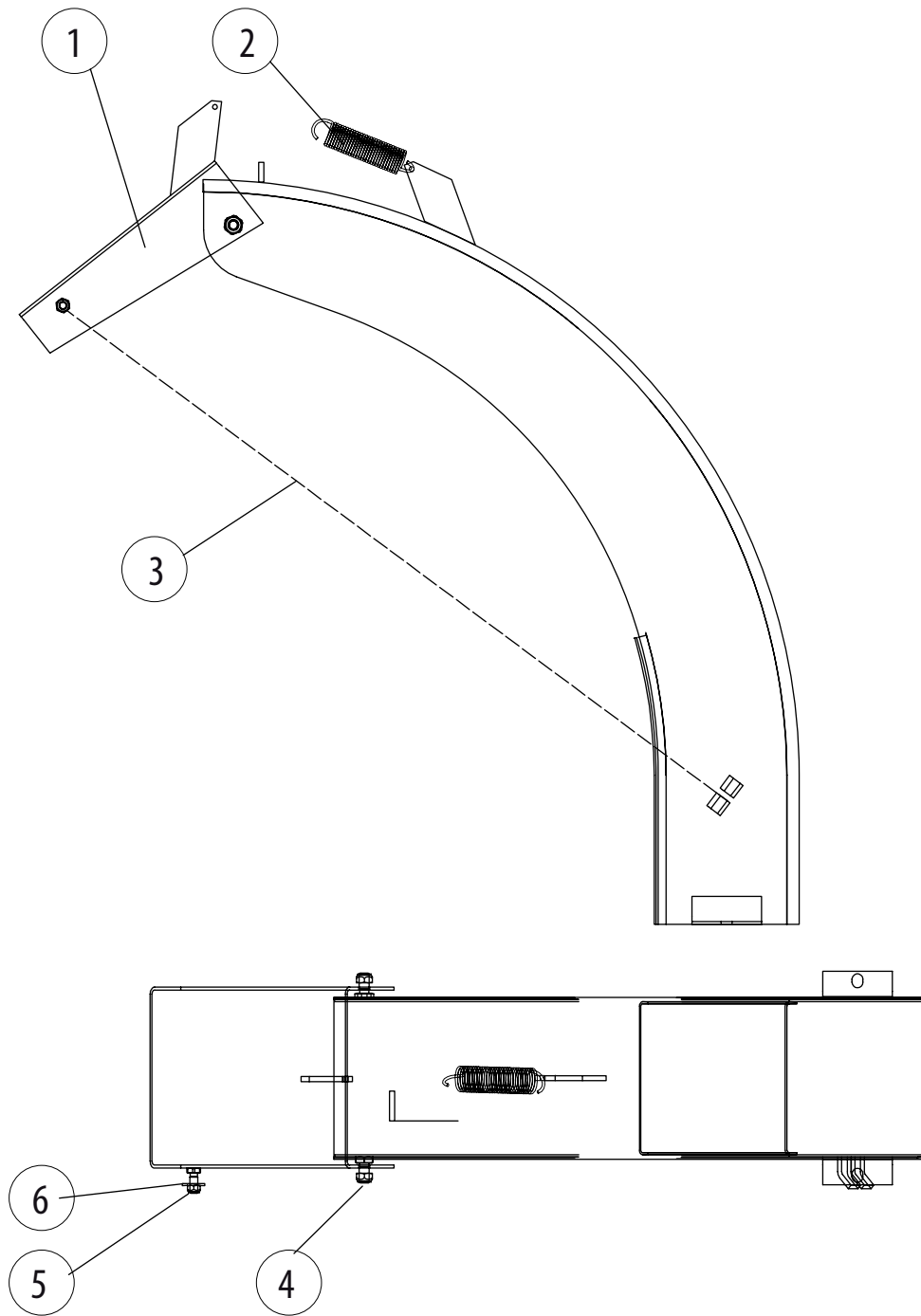

| Part | Order no | Description | Remarks | Qty |
|------|----------|----------------|----------------|-----|
| | 33620400 | Discharge pipe | complete | 1 |
| 1 | 43510240 | Vizer | | 1 |
| 2 | 94612082 | Tension spring | | 1 |
| 3 | 03514590 | Chain | | 1 |
| 4 | 52117108 | Lock nut | M10 DIN985 8ZN | 2 |
| 5 | 52117082 | Lock nut | M8 DIN985 8ZN | 1 |
| 6 | 52200037 | Washer | M8 DIN126 58ZN | 1 |

HYDRAULIC MOTOR AND HOSES

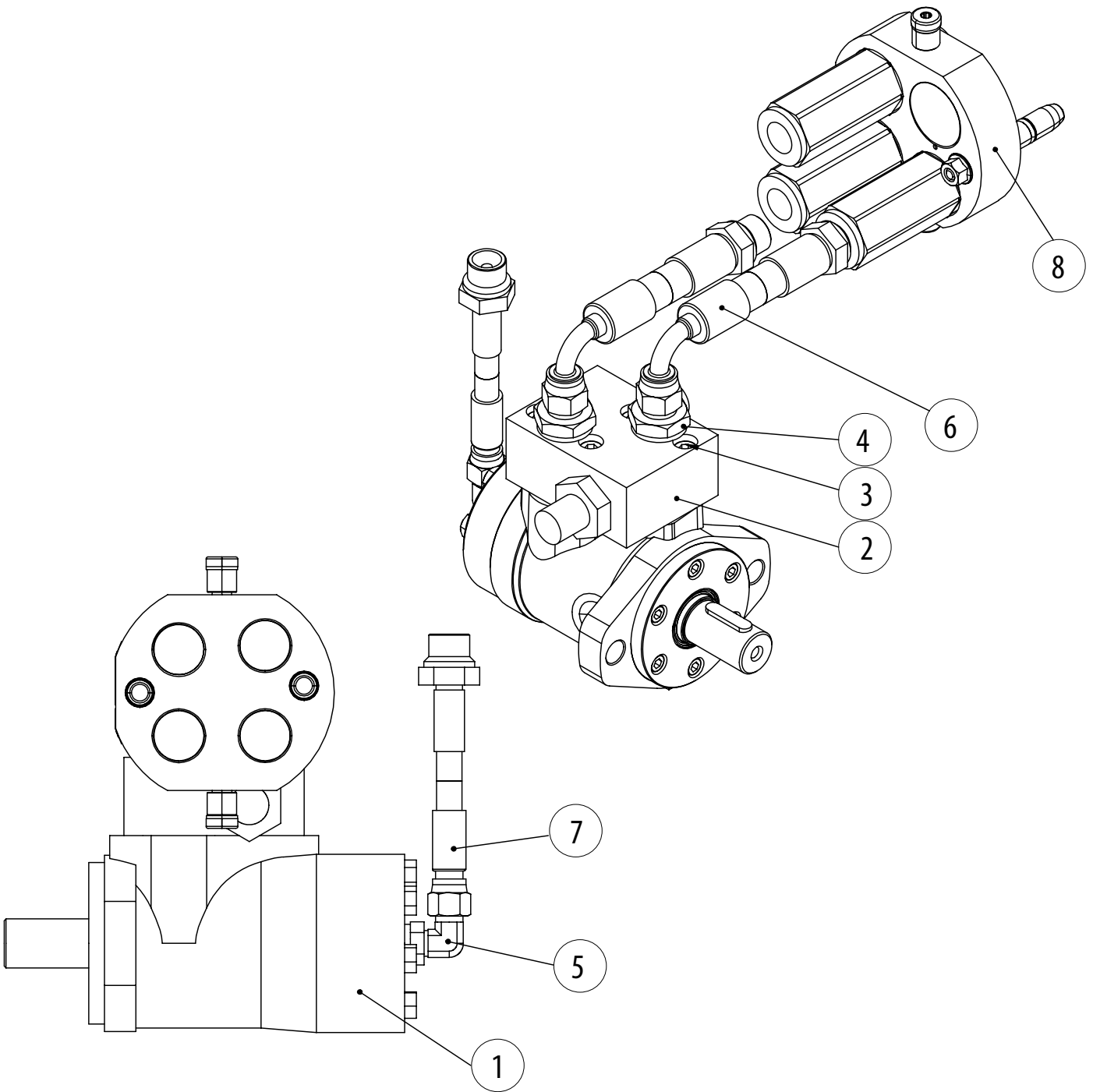

| Part | Order no | Description | Remarks | Qty |
|------|----------|-----------------------|--------------------|-----|
| 1 | 56001310 | Hydraulic motor | M+S | 1 |
| 2 | 56001320 | Pressure relief valve | 80 bar | 1 |
| 3 | 52001280 | Screw | M12X20 DIN933 88ZN | 4 |
| 4 | 52450020 | Basic connector | 1/2" | 1 |
| 5 | 52450030 | Angle connector | 1/2" | 1 |
| 6 | 43621330 | Hydraulic hose | L=1350 | 2 |
| 7 | 43621340 | Hydraulic hose | L=1350 | 1 |
| 8 | 03621350 | Multiconnector | 1/2" | 1 |

CH100 HYDRAULIC OPERATION

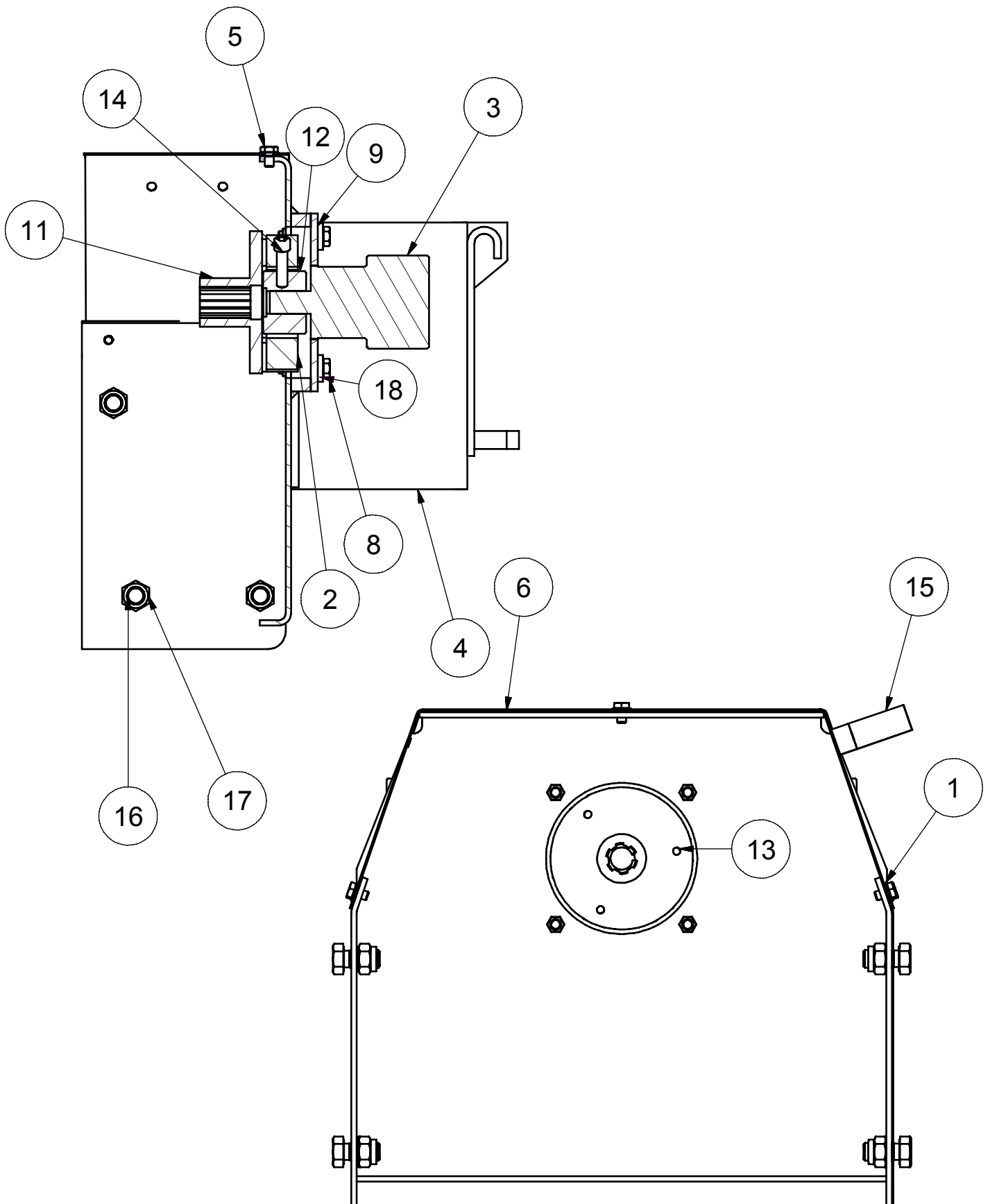

CH100 HYDRAULIC OPERATION

| Part | Order no | Description | Remarks | Qty |
|------|----------|---------------------------------------|---------------------|-----|
| 1 | 52200045 | Washer | M10 DIN125 58ZN | 5 |
| 2 | 03621280 | Centaflex 16 | Kumikytkin R1/2" | 1 |
| 3 | 56001310 | Hydraulic motor | M+S | 1 |
| 4 | 33621000 | Avant-adapter | | 5 |
| 5 | 52060209 | Screw | M10X16 DIN933 88ZN | 5 |
| 6 | 43620970 | Protective Arc | | 1 |
| 7 | 52214269 | Locking plate | M12 NORD-LOCK | 2 |
| 8 | 52063161 | Screw | M12x180 DIN931 88ZN | 6 |
| 9 | 43621370 | Motor mounting plate | | 1 |
| 10 | - | - | - | - |
| 11 | 43621290 | flange | | 1 |
| 12 | 43621270 | Coupling hub | | 1 |
| 13 | 52001237 | Screw | M12x30 DIN933 10.9 | 3 |
| 14 | 52001237 | Screw | M12x30 DIN933 10.9 | 3 |
| 15 | 53621230 | Multi connector Parking on attachment | | 1 |
| 16 | 52062213 | Screw | M20X40 DIN933 88ZN | 6 |
| 17 | 52117207 | Lock nut | M20 DIN985 8ZN | 6 |
| 18 | 52200490 | Washer | M12 DIN 7349 ZN | 4 |



AVANT[®]

Avant Tecno Oy
Ylötie 1
FIN-33470 YLÖJÄRVI, FINLAND
Tel. +358 3 347 8800
sales@avanttecno.com

AVANT has a policy of continuing improvement, and retains the right to change specifications without notice. © 2017 AVANT Tecno Oy. Kaikki oikeudet pidätetään.

www.avanttecno.com